

A SPECIALIST IN
IN-HOUSE MATERIAL HANDLING



HelgeNyberg AB

A SPECIALIST WITH INNOVATIVE VISIONS

We haven't been manufacturing trolleys and light electric trucks since 1958 just because we can. The real reason is that we've seen a need for our solutions. That's a significant difference. Naturally, we've got the craftsmanship. You can be sure of that. But more important still: the company's founder, Helge Nyberg, started making trolleys to meet a need he noticed first-hand at Volvo's parts warehouse. This means we have a shared history with our customers. We're not only specialists in our products – we're also specialists in your everyday work situation.

That's why focusing on trolleys and trucks are not our visions for the future. Instead, our visions are about finding the best way to rationalise work procedures and costs for warehouses and light material handling logistics. As long as we can do this with trolleys and trucks, we will concentrate on optimising that technology. But who knows? Ergobjörn may concentrate on completely different solutions in the future. All we know for sure is that the future is the only time we have the power to influence. And we intend to do just that.

OUT TOMORROW'S TROLLEYS AND TRUCKS



We have produced many trolleys, trucks and innovations since 1958. But we never sit back and rest on our laurels. We are constantly seeking the next solution to rationalise our customers' business. Today it's an automatic towing truck. Tomorrow who knows?

LEAN MANAGEMENT IS

Lean production, kanban systems, just-in time, milk runs, flow orientation, the pull and push method – there are many different concepts and approaches to production and warehouse logistics. But it all boils down to getting the right material to the right place at the right time. It's as simple as that for Helge Nyberg AB.

For over half a century, Ergobjörn products have been rationalising work procedures and raising companies' profitability through in-house transportation of goods. Since we started in 1958, we have focused on optimising efficiency and ergonomics for our users. Lean management is nothing new to us. We have always aimed to minimise waste of material, time and human resources – both at our own premises and at those of our customers in over 60 countries. We're not satisfied with making good products. A Helge Nyberg solution must always give our customers added value. Until that criterion is met, no product leaves our development department or production facilities. It's as simple as that.



The staff at the workshop liked the idea and built the trolley. The trolleys built over the following years are still operating at many of our customers' premises. Helge Nyberg has since become a specialist company that manufactures and develops trolleys and electrical trucks under the name of Ergobjörn – a brand that is well-known worldwide among companies performing in-house material handling in warehousing and logistics applications.

PRODUCT RANGE: "ONLY ERGOBJÖRN IS ALLOWED HERE"

Lean production requires flexible solutions that do not impose limits on the user. This is why we have a module-based product programme for the entire gamut of in-house material handling. We can deliver trolleys in a virtually infinite number of variants, including motor driven, for even better



"Helge Nyberg has since become a specialist company that manufactures and develops trolleys and electrical trucks under the name of Ergobjörn."

HISTORY: HOW DID IT ALL START?

In 1958, Helge Nyberg was an employee at Volvo's parts warehouse in Ulricehamn, Sweden. He was sure there must be a way of rationalising the order picking process. He drew a design for a trolley equipped with steps and an order holder.

ergonomics and productivity. Our range of electric trucks also makes us market specialists. Although they are very light, these trucks have a high towing capacity. As a result, many customers with mezzanine floors in their warehouses only allow the use of lightweight Ergobjörn trucks. Furthermore, our unique concept of truck-towed trolleys has given our customers enormous flexibility, allowing fast switching between tasks at their warehouses and production facilities. We are dedicated to our mission to streamline warehouses and factories around the world with our smart specialised solutions.



The idea for our smart trolleys was born when the company's founder Helge Nyberg was working at Volvo's parts warehouse.

People's working environment and ergonomics are given factors in our product development and logistic solutions.

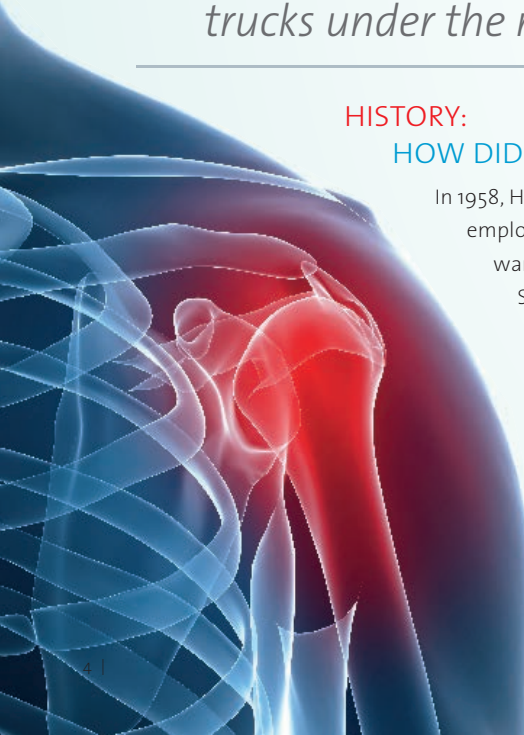

NO NEWS TO US

ERGONOMICS: YOUR EMPLOYEES' HEALTH IS IMPORTANT TO US

It is vital to focus on employees when making rationalisation decisions. Failure to do this leads to both long-term and short-term costs. Taking an ergonomic approach is the only viable option, from both a human and an economic perspective.

It reduces sick leave and rehabilita-

tion costs and facilitates recruitment of skilled employees. This is why ergonomics play a key role in all aspects of Helge Nyberg's product development. Among other things, this can be seen in our adjustable handles, shelves and user-friendly controls, and in our trucks and steps with the correct dimensions and heights. All our ergonomic solutions are based on knowledge and research regarding people's physical and psychological conditions. In a word, we aim to make our products as user-friendly and cost-effective as possible.

WARRANTY: HOW OLD CAN A TROLLEY GET?

Maybe the quality of our trolleys and trucks is too high for our own good. But it gives us enormous satisfaction when we visit customers and discover that they're still using the same trolleys we made and supplied to them more than 50 years ago. This shows that both we and the customer got it right. It gives us satisfied customers that we can grow and develop with. Our lifetime guarantee proves the quality of our standard trolleys. If they start breaking down after a couple of hundred years, we may need to revise this warranty. In the end, it's never quality that costs – it's the lack of it. Read more about our secure warranty conditions on page 100.



The first trolley developed and manufactured by Helge Nyberg in 1958 is still operating at our showroom. You're welcome to drive it when you visit us.



Helge Nyberg was one of the world's first industrial companies to certify its work environment (AFS 2001:1). We also have quality and environmental certification according to ISO 9001 and ISO 14001.

ENVIRONMENT: ISO 14001 OR FRESH PERCH FROM THE LAKE

Yes, we have all the necessary certificates for quality, environmental care and working environment – ISO 9001, ISO 14001 and AFS 2001:1 (and we were one of the first industrial companies in the world to certify our work environment). However, our best environmental

warranty on all is that we live in the same geographical area that our production is located in. The skiing complex where we take our children in the winter is just a couple of hundred metres north-west of the factory. Less than 500 metres in the other direction are the small town where we live and the lake where we go swimming. This is the environment where Helge Nyberg's Ergobjörn trolleys and trucks are developed and produced. We wouldn't risk that environment for anything. Come and visit us. If you're lucky, you might get newly caught fried perch for lunch.



CUSTOMISATION: TAILOR-MADE SOLUTIONS BECOME STANDARD

Making our customers' material handling as rational as possible may mean creating tailor-made solutions for them. These solutions sometimes become standard models in our wide product range. For this reason, we are not averse to receiving customisation requests. Quite the contrary, in fact. By collaborating closely with a wide range of customers and industries with diverse needs and requirements, we have built up unique specialist expertise over half a century. This has

given us expertise and experience you can rely on. We know what we can do – and what we can't. That's what distinguishes a specialist from other players in the market.



With in-house development and production in Ulricehamn, Sweden, we can always warranty the right quality and function in everything we do.

HELGE NYBERG AB HAS THE SOLUT

Although all our customers have the same basic need for cost-effective, ergonomic material handling, their needs may differ on crucial points and key details. Moreover, different industries often have different laws and regulations for products, certifications or other industry-specific requirements. For this reason, we have specialised in a number of areas on the basis of over 55 years' collective experience and knowledge of our customers' needs. This allows us to offer the optimum solutions, the best service and the most secure collaboration.

A SPECIALIST WITH CONCEPTS FOR MANY APPLICATION AREAS



INDUSTRY & MANUFACTURING

Helge Nyberg operates in both light and heavy industries. We have industrial solutions for the entire material flow.



MAIL ORDER & DISTRIBUTION

With our long history and our location in a geographic area that is dense with mail order, eCommerce and logistics and warehousing businesses, we have unique know-how and experience regarding order picking and third party logistics.



HEALTH CARE & HOSPITAL

All industries have different requirements and specifications regarding materials and professional equipment. The strictly regulated health care sector has certain specific requirements. We can meet these requirements.



AUTOMOTIVE & VEHICLE

The development of smart logistics is perhaps most advanced in the automotive industry. Helge Nyberg's solutions are part of this development.



SERVICE & SUPPORT

Our truck and trolley solutions are not only ideal for transporting baggage or materials, for instance at airports and trade fairs. They are just as frequently used as wheeled service points by technicians and installers, for example in factories.



LEAN SOLUTIONS

As specialists, we are happy to help you develop the most resource-efficient solution to your material handling needs – the right material, in the right place at the right time.

IONS TO YOUR NEEDS



COLLABORATION WITH ENDLESS POSSIBILITIES

It is virtually impossible to summarise a company's visions, solutions and offering in a catalogue. With more than 55 years in the industry as Scandinavia's leading manufacturer, and with customers in over 60 countries, we have a lot to say for ourselves. We have attempted a summary, and hope this catalogue will whet your appetite for what a collaboration with Helge Nyberg can offer you. In the catalogue, you will learn about the benefits of our products, know-how, warranties and services.

I would personally like to mention two of these benefits. One is the economic value of rationalising the costs of production and in-house logistics; the other is that your employees' backs and joints will benefit enormously from our ergonomic solutions. This is because the risk of harmful lifts and movements is minimised as a direct consequence of improved material handling solutions. Ergonomics and people's health have always played an integral role in our development of products and solutions.

Naturally, it is also vital that you can always get customised solutions that suit your needs. Players without their own development and production often regard customised solutions as a problem. Helge Nyberg takes the opposite view. Our success and high customer confidence are largely based on the fact that over the years, we have developed customised solutions that have later been integrated into our standard range. So don't hesitate to contact us if the solution you're looking for isn't in the catalogue. I would be very surprised if we can't quickly offer you an excellent solution.



CEO Peter Sprigg

ERGOBJÖRN – FOR FAST, SM MATERIAL HANDLING

Helge Nyberg has been manufacturing trolleys and trucks since 1958. Five decades later, trolleys delivered back then are still in operation at many warehouses. They're known as "Helge trolleys". Today, the name Ergobjörn is displayed on the products manufactured at our factory for customers worldwide. The quality remains the same: the very highest.



TROLLEYS FOR TRUCKS

We have a broad and detailed range of trolleys for trucks. Our unique docking system allows different trolley models to be used with the same truck.

p. 10-12



TAXI FLEX

The perfect solution for material handling. Manoeuvrable, versatile and efficient, with internal trolleys that can also be used separately.

p. 13 & 18-19

TAXI SOLUTIONS

Solutions that allows several trolleys to be towed together in a train. This gives you fewer internal consignments with fork lift truck and so reduces the risk of accidents. The taxi solutions can be combined with many of our other trolleys.

p. 14-21



ART, PRACTICAL



TROLLEYS

Using the right trolley facilitates order picking and handling of a diverse range of goods including books, paintings, industrial products and pharmaceuticals.

p. 22-73



SCOOTERS AND PEDAL BIKES

We have two- and three-wheeled bikes for transportation over large distances. Available with or without a platform.

p. 60-63



CUSTOMISED SOLUTIONS

If you don't find the product you need in our wide range, we can always develop a customised solution for you. There are many advantages of having your own manufacturing facilities and R&D department.

p. 74-75



CUSTOMISED TO YOUR NEEDS

TROLLEYS FOR TOWING TRUCKS

All our trolleys have a capacity of 500 kg. With their excellent ergonomics and high quality, they help improve the profitability of companies that handle light goods in-house. Thanks to a wide range of wheel types, shelf sizes etc., the trolleys are extremely flexible and easy to adapt to the job at hand. There are approximately 600 trolleys in our standard range. By combining them with smart accessories, they can be customised to suit most needs. A shelf edge and an end grid keep the cargo firmly in place at all times. Tow bar and tow hook included. Chassis of 22 mm round, shiny zinc-coated tubing. 12 mm shelves with light grey laminate finish. Continuously height-adjustable handles made of powder-coated 22 mm tubing.



SHELF TROLLEY

The ends and shelves are reinforced to withstand loads up to 500 kg. The end uprights are held together by a top element. Lower shelf is recessed in the frame profile. Shelves reinforced with shelf supports. Upper shelves are continuously height-adjustable. Upper shelves have a 25x20 mm edge profile that creates a 10 mm high edge along the lateral sides. Max. load 500 kg. Lower shelf has a max. load of 500 kg.

Upper shelves have a max. load of 150 kg. Two fixed wheels and two swivel wheels with grey elastic rubber tyres measuring 200x50 mm, ball bearing hubs.

Model 25 – low ends, 2 shelves
Model 27 – high ends, 3 shelves

Model 25					
Art. no.	Shelves	Shelf dim.	Length	Width	Height
15250680	2	800x600	1000	650	1180
15251680	2	1000x600	1200	650	1180
15252680	2	1200x600	1400	650	1180
15254680	2	1400x600	1600	650	1180
15256680	2	1600x600	1800	650	1180
15251780	2	1000x700	1200	750	1180
15252780	2	1200x700	1400	750	1180
15254780	2	1400x700	1600	750	1180
15256780	2	1600x700	1800	750	1180
15251880	2	1000x800	1200	850	1180
15252880	2	1200x800	1400	850	1180
15254880	2	1400x800	1600	850	1180
15256880	2	1600x800	1800	850	1180

Model 27					
Art. no.	Shelves	Shelf dim.	Length	Width	Height
15270680	3	800x600	1000	650	1860
15271680	3	1000x600	1200	650	1860
15272680	3	1200x600	1400	650	1860
15274680	3	1400x600	1600	650	1860
15276680	3	1600x600	1800	650	1860
15271780	3	1000x700	1200	750	1860
15272780	3	1200x700	1400	750	1860
15274780	3	1400x700	1600	750	1860
15276780	3	1600x700	1800	750	1860
15271880	3	1000x800	1200	850	1860
15272880	3	1200x800	1400	850	1860
15274880	3	1400x800	1600	850	1860
15276880	3	1600x800	1800	850	1860



Push brake available as accessory

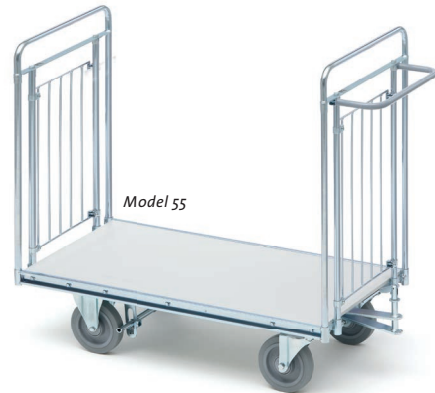

PLATFORM TROLLEY

The ends and shelves are reinforced to withstand loads up to 500 kg. The end uprights are held together by a top element. The shelf is recessed in the frame profile. Max. load 500 kg. Two fixed wheels and two swivel wheels with grey elastic rubber tyres measuring 200x50 mm, ball bearing hubs.

Model 54 – one end panel, detachable tubular frame on back
 Model 55 – two end panels

Model 54					
Art. no.	Shelves	Shelf dim.	Length	Width	Height
15540680	1	800x600	1000	650	1180
15541680	1	1000x600	1200	650	1180
15542680	1	1200x600	1400	650	1180
15544680	1	1400x600	1600	650	1180
15546680	1	1600x600	1800	650	1180
15541780	1	1000x700	1200	750	1180
15542780	1	1200x700	1400	750	1180
15544780	1	1400x700	1600	750	1180
15546780	1	1600x700	1800	750	1180
15541880	1	1000x800	1200	850	1180
15542880	1	1200x800	1400	850	1180
15544880	1	1400x800	1600	850	1180
15546880	1	1600x800	1800	850	1180

Model 55					
Art. no.	Shelves	Shelf dim.	Length	Width	Height
15550680	1	800x600	1000	650	1180
15551680	1	1000x600	1200	650	1180
15552680	1	1200x600	1400	650	1180
15554680	1	1400x600	1600	650	1180
15556680	1	1600x600	1800	650	1180
15551780	1	1000x700	1200	750	1180
15552780	1	1200x700	1400	750	1180
15554780	1	1400x700	1600	750	1180
15556780	1	1600x700	1800	750	1180
15551880	1	1000x800	1200	850	1180
15552880	1	1200x800	1400	850	1180
15554880	1	1400x800	1600	850	1180
15556880	1	1600x800	1800	850	1180



PARCEL TROLLEY

The ends and shelves are reinforced to withstand loads up to 500 kg. The uprights are held together by a top element. Side gates are easily opened. The shelf is recessed in the frame profile. Max. load 500 kg. Two fixed wheels and two swivel wheels with grey elastic rubber tyres measuring 200x50 mm, ball bearing hubs.

Art. no.	Shelves	Shelf dim.	Length	Width	Height
15861680	1	1000x600	1200	650	1180
15862680	1	1200x600	1400	650	1180
15864680	1	1400x600	1600	650	1180
15866680	1	1600x600	1800	650	1180
15861780	1	1000x700	1200	750	1180
15862780	1	1200x700	1400	750	1180
15864780	1	1400x700	1600	750	1180
15866780	1	1600x700	1800	750	1180
15862880	1	1200x800	1400	850	1180
15864880	1	1400x800	1600	850	1180
15866880	1	1600x800	1800	850	1180

ACCESSORIES – TROLLEYS FOR TOW TRUCKS



MEMO BOARD

With document clip. Type 1 is mounted with clips, type 2 is mounted with an adjustable holder. Pen tray at top. Portrait A4.

Art. no.	Description
12200220	Type 1 with clip
12212220	Type 2 with adjustable holder



PUSH BRAKE

The brake is activated on the rear wheel of the trolley. Increases towing capacity up to 1000 kg in a train of trolleys.

Art. no.	For trolley
12253360	1200x600
12253382	1200x800

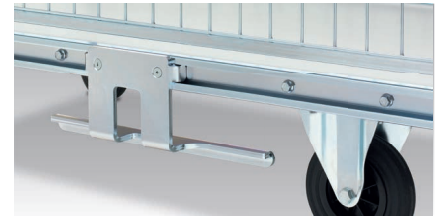

TRUCK FORK GUIDE

For handling trolleys from long side. Please specify distance between the truck forks and the forks' height at highest point when ordering.

Art. no.
12253301



PROTECTIVE EDGING STRIP

An edging strip that can be mounted on trolleys to protect them and prevent them from hooking onto each other. The strip is 33 mm and increases the trolley width by 25 mm per side.

Art. no.	For shelf length
12253200	800 mm
12253210	1000 mm
12253220	1200 mm
12253240	1400 mm
12253260	1600 mm

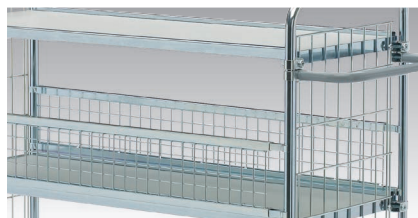

GRID RAIL

Easy to mount and dismantle. Mesh size: 30x30 mm. Height: 161 mm.

Art. no.	For shelf length
12212163	800 mm
12212165	1000 mm
12212168	1200 mm
12212169	1400 mm
12212170	1600 mm

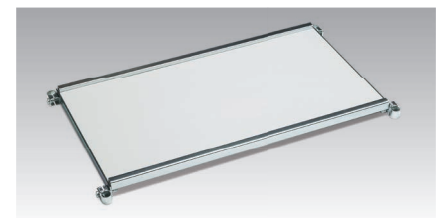

EXTRA SHELVES, MODELS 25 AND 27

Grey 12 mm laminate panel. Profiles and mounting parts included.

Art. no.	Shelf dim.
12252406	800x600
12252416	1000x600
12252426	1200x600
12252446	1400x600
12252466	1600x600
12252417	1000x700
12252427	1200x700
12252447	1400x700
12252467	1600x700
12252418	1000x800
12252428	1200x800
12252448	1400x800
12252468	1600x800



SHELF PARTITION

Easy to move and remove. Wire distance: 34 mm. Cannot be mounted on chassis shelf. Fits trolleys with width of 600 mm.

Art. no.	For shelf length
12232142	800 mm
12212145	1000 mm
12212148	1200 mm
12212149	1400 mm
12212150	1600 mm



SHELF PARTITION

Easy to move and remove. Wire distance: 34 mm. Cannot be mounted on chassis shelf. Fits trolleys with width of 600 mm.

Art. no.	Dimensions
12200106	600x220

INNOVATIVE SOLUTIONS FOR MATERIAL HANDLING

TAXI FLEX

We have several different types of solutions for handling trains of trolleys. Among the smartest are taxi solutions that work with various kinds of internal trolleys. The advantages of Taxi Flex, as the name suggests, are flexibility and convenience. You can either tow several trolleys in a train even where space is limited, or you can handle trolleys separately outside the train. The solution is suitable for shop and order picking, material replenishment, laundry and waste handling within the food industry, factories, hotels, laundries and hospitals.



LAUNDRY AND WASTE HANDLING

Convenient solution for transporting laundry trolleys, for example.



MATERIAL REPLENISHMENT

Taxi trolley with two internal trolleys for LEAN handling of pre-kitted trolleys.



CONTAINER HANDLING

Transport up to two containers in one Taxi and couple several Taxi trolleys together into an efficient train.

For more details, see pages 18-19. You are also welcome to contact our sales department at info@helge-nyberg.com, or call +46 321 263 00.

INTERNAL TRANSPORT WITHOUT FORKLIFTS

TAXI SOLUTIONS

With this smart solution, several different trolleys can be transported in a train at the same time, which minimises the number of transports and increases the frequency of goods delivery for the production department. Less number of internal transports (often one-way) reduces the risk of accidents in the production premises. Heavy fork-lift trucks can be replaced with smaller and flexible towing trucks, providing effective milk-runs. The Taxi solution can also be combined with other trolleys from our range.







TAXI

The Taxi solution means that up to four Taxi trolleys can be connected in a train, where each trolley can carry 600 kg maximum. The number of trolleys depends on the truck's towing capacity. In every Taxi trolley there is room for either a whole pallet dolly (1210x820 mm) or two half pallet dollies (620x810 mm). The dolly construction also provides the possibility to build other trolleys depending on customers' needs- from simple pallet trolleys to advanced "Kit-Trolleys". This increases both the efficiency and the flexibility. During transport, the wheels of the dollies are raised from the floor, which means that it is possible to use different combinations of wheels, in different qualities, according to needs. This solution also makes it possible to use different combinations of fixed and swivel wheels.



Lifting Device

Easy manoeuvrable electric lifting device which raises the dollies from the floor during transport.



Locking the Dollies

A foot-manoeuvrable locking function which keeps the dollies in place during transport.

Dimensions and technical data, 2-wheel steering

Art. no.	14902293
Load capacity per trolley	600 kg
Weight	165 kg
Length	1791 mm
Width	964 mm

Electricity supply

Electric actuators	24 VDC
Power for the Taxi is taken from the truck then passed from trolley to trolley.	

Miscellaneous

Max. speed loaded	7 km/h
Maximal train weight	2400 kg
Wheel design	Polyuretan ø 150 mm 2 fasta, 2 länk
Tow bar eye diameter	ø 23 mm

The Taxi can be set up so the trolleys can loaded from the right or the left. **For safety reasons, only trolleys manufactured by Helge Nyberg AB can be used, because of the locking function. The two-wheel steered Taxi has a tow bar at the back. The truck is fitted with a tow bar. The four-wheel steered Taxi has a tow bar at the front.**

Dimensions and technical data, 4-wheel steering

Art. no.	14902294
Load capacity per trolley	600 kg
Weight	170 kg
Length	1791 mm
Width	964 mm

Electricity supply

Electric actuators	24 VDC
Power for the Taxi is taken from the truck then passed from trolley to trolley.	

Miscellaneous

Max. speed loaded	7 km/h
Maximal train weight	2400 kg
Wheel design	Polyuretan ø 150 mm 4-hjulsstyrda länkhjul
Tow bar eye diameter	ø 23 mm

The Taxi can be set up so the trolleys can loaded from the right or the left. **For safety reasons, only trolleys manufactured by Helge Nyberg AB can be used, because of the locking function. The two-wheel steered Taxi has a tow bar at the back. The truck is fitted with a tow bar. The four-wheel steered Taxi has a tow bar at the front.**



FULL PALLET DOLLY

Dolly with four swivel wheels for individual easy and flexible handling when disconnected from the train. Can be fitted with different kinds of wheels and brakes. Maximum load is 600 kg for each dolly.

Art. no.	Max. pallet size	Wheels
14902122	1250x840 mm	Nylon ø 160 mm



HALF PALLET DOLLY

When using half pallets, two dollies can be transported at the same time which enables KANBAN principles when switching between full and empty applications. With four swivel wheels for individual easy and flexible handling when disconnected from the train. Can be fitted with different kinds of wheels and brakes. Maximum load is 300 kg for each dolly.

Art. no.	Max. pallet size	Wheels
14902123	840x620 mm	Nylon ø 160 mm



SHELF SYSTEM

Different types of shelf systems increases the flexibility for transporting various types of goods with the same load carrier. The shelf system can be attached to whole pallet dollies and easily be lifted off as well. The shelves are adjustable.

Art. no.	Inside dimensions of shelf
14902124	1215x820 mm

EFFICIENT INTERNAL TRANSPORT

TAXI FLEX

The Taxi trolley can hold two internal trolleys at the same time and can be towed behind a truck in a train of several Taxi trolleys. A unique 4-wheel steering system ensures that the Taxi trolleys run smoothly and track well in the train. This is an advantage, and in many cases a must, in narrow corridors and aisles, in hospitals for example. The internal trolleys have four swivel wheels, making them easy to manoeuvre and suitable for use as individual manual trolleys as well. The Taxi trolleys with internal trolleys can be uncoupled from the Taxi with the internal trolleys in place and manoeuvred manually, in and out of lifts for example.





To find out more about our smart distribution solutions, please contact our sales department at info@helge-nyberg.com, or call +46 321 263 00.

THE SOLUTIONS OF THE FUTURE ARE HERE

SMART AND EFFICIENT DISTRIBUTION

With our distribution solution, you can pick with docked wheeled containers in very narrow aisles. The truck can also be driven on mezzanine floors and into lifts. It can also be coupled to one or more Taxi trolleys and so transport up to seven wheeled containers at once. Articulated couplings mean that even such long trains still track well in confined spaces.





To find out more about our smart distribution solutions, please contact our sales department at info@helge-nyberg.com, or call +46 321 263 00.

FLEXIBLE TROLLEY SOLUTIONS WORK SIMPLE AND FAST

Our trolleys rationalise and facilitate work procedures in all situations that require in-house handling of materials – whether those materials are industrial products, books or pharmaceuticals. By combining our trolleys with the right accessories, you can create the exact solution you need. Thanks to a wide range of wheel types, shelf sizes etc., the trolleys are extremely flexible and easy to adapt to specific tasks according to the needs of your business.



WHY CHOOSE AN ERGOBJÖRN TROLLEY?

- Lifetime warranty on standard trolleys
- The market's most durable surface coating
- Modular system – allows a virtually unlimited number of versions to be created
- Adjustable handles and shelves
- Our trolleys roll easily with different loads and in all directions
- Many smart accessories to choose between to optimise your solution

MAKE YOUR

TROLLEYS CUSTOMER SOLUTIONS



Volvo hardly needs an introduction. The company uses Helge Nyberg standard trolleys to transport material to their production lines for assembly and installation.



French mail order company Yves Rocher supplies cosmetics worldwide, and their warehouse requires maximum efficiency. Our practical electric trolleys solved their order picking needs.

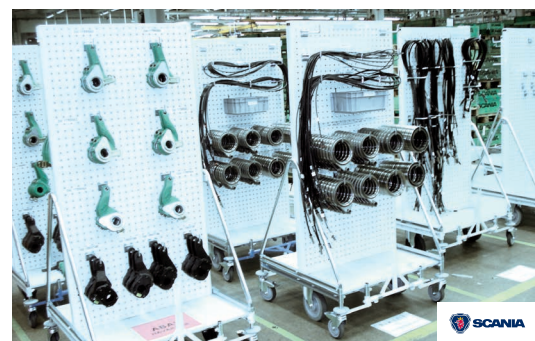

Scania, one of the world's leading truck and bus manufacturers, chose Helge Nyberg batch picking trolleys to transport materials from their warehouse to assembly stations.

SMART ADJUSTABLE SHELVES

SHELF TROLLEYS

Thanks to continuously adjustable shelves and handles, the trolleys are easily adapted to different needs. Shelves are adapted to standard boxes (600x400 mm). There are three different wheel designs for maximum driving comfort. Four swivel wheels allow the trolley to roll in all directions. Two swivel wheels and two fixed wheels provide optimum driving stability. A support wheel system (two wheels positioned centrally underneath the trolley) makes the trolley easy to turn even with a heavy load. Shelf edges and end grids keep the cargo firmly in place. The chassis is made of 22 mm shiny zinc-coated tubing. The trolleys have hardwearing 12 mm shelves, reversible and detachable, with a light grey laminate finish.



SHELF TROLLEY SERIES 100

Shiny zinc-coated shelf edge profiles 25x20 mm. Max. load: 200 kg. Max. load, shelves: 100 kg. Four swivel wheels with grey rubber tyres measuring 125x32 mm, ball bearing hubs and safety guard.

TROLLEY WITH GRIDS SERIES 100

Shelf profile of shiny zinc-coated 19 mm tubing. Grid with grid mesh 24x100 mm. Max. load: 200 kg. Max. load, shelves: 100 kg. Four swivel wheels with grey rubber tyres measuring 125x32 mm, ball bearing hubs and safety guard.

Art. no.	Shelves	Shelf dim.	Length	Width	Height
24112222	2	620x425	800	460	1120
24112322	2	750x425	930	460	1120
24112522	2	1000x425	1180	460	1120
24112622	2	1200x425	1380	460	1120
24112232	3	620x425	800	460	1120
24112332	3	750x425	930	460	1120
24112532	3	1000x425	1180	460	1120
24112632	3	1200x425	1380	460	1120
24112242	4	620x425	800	460	1585
24112342	4	750x425	930	460	1585
24112542	4	1000x425	1180	460	1585
24112642	4	1200x425	1380	460	1585

Art. no.	Shelves	Shelf dim.	Length	Width	Height
24117322	2	750x450	930	460	1120
24117522	2	1000x450	1180	460	1120
24117622	2	1200x450	1380	460	1120
24117332	3	750x450	930	460	1120
24117532	3	1000x450	1180	460	1120
24117632	3	1200x450	1380	460	1120
24117342	4	750x450	930	460	1585
24117542	4	1000x450	1180	460	1585
24117642	4	1200x450	1380	460	1585

Extra shelves series 100		Extra shelves grid trolley series 100	
Art. no.	Shelf dim.	Art. no.	Shelf dim.
12210210	620x425	12210311	750x425
12210310	750x425	12210511	1000x425
12210510	1000x425	12210611	1200x425
12210610	1200x425		



SHELF TROLLEY SERIES 100 – POPULAR

Shiny zinc-coated shelf edge profiles 25x20 mm. Max. load: 150 kg. Max. load, shelves: 100 kg. Four swivel wheels with grey rubber tyres measuring 125x28 mm, slide bearing hubs.

Art. no.	Shelves	Shelf dim.	Length	Width	Height
24119030	2	750x425	900	425	890
24119050	2	1000x425	1150	425	890



Art. no.	Shelves	Shelf dim.	Length	Width	Height
24121224	2	850x520	1130	520	1110
24121324	2	850x620	1130	620	1110
24121624	2	1250x620	1530	620	1110
24121234	3	850x520	1130	520	1110
24121334	3	850x620	1130	620	1110
24121634	3	1250x620	1530	620	1110

SHELF TROLLEY SERIES 200

A support wheel system (two wheels positioned centrally underneath the trolley) makes the trolley easy to manoeuvre and turn, even with a heavy load. Shelf profile of 22 mm round, shiny zinc-coated tubing. Max. load: 300 kg. Max. load, shelves: 150 kg. Three or four swivel wheels with grey rubber tyres measuring 125x32 mm, ball bearing hubs and safety guard. Two centrally positioned wheels with black elastic rubber tyres measuring 200x50 mm, roller bearing hubs.

End grid mesh size 100x50 mm

Art. no.	Height
12200140	600
12200144	800

ACCESSORIES – SERIES 100 & 200 SHELF TROLLEYS



MEMO BOARD

With document clip. Type 1 mounted with clips, type 2 mounted with adjustable holder. Pen tray at top. Portrait A4.



PEN TRAY

Two models.

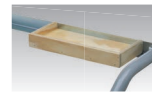

Art. no.	Description
12200220	Type 1 with clip
12212220	Type 2 with adjustable holder

Art. no.	Description
12200221	Single, 180x80 mm
12200225	Double, 310x80 mm

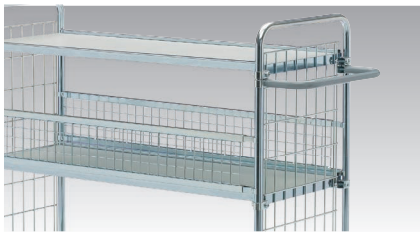

GRID RAIL

Easy to mount and dismantle. Mesh size: 30x30 mm. Height: 161 mm. Only fits series 100.



BASKET

For mounting on end. Mesh size at base 25x25 mm, open corners and 25x85 mm at end.



SIDE GRID

Easy to mount and dismantle. Mesh size: 65x50 mm. Height 620 mm. Two grids are needed for trolleys with high ends. Only fits series 100.

Art. no.	For shelf length
12212162	750 mm
12212165	1000 mm
12212168	1200 mm

Art. no.	Dimensions
12200245	150x330x180 mm

Art. no.	For shelf length
12212140	600 mm
12212142	750 mm
12212145	1000 mm
12212148	1200 mm

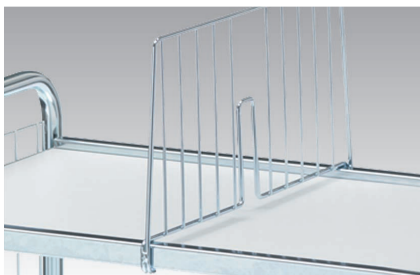

SHELF PARTITION

Easy to move and remove. Wire distance: 34 mm. Not compatible with grid shelves.



BOX

Pulls out. Can be mounted on right or left side. Only fits series 100.



SAFETY WHEELS

Protects trolleys, shelves and walls from damage. Set of four wheels for mounting on corner uprights. Only compatible with series 100. Only available when ordering new trolleys.

Art. no.	Dimensions
12200104	420x220

Art. no.	Dimensions
12200440	370x150x100

Art. no.
12212010

SHELF TROLLEY BLACK – 3 SHELVES

Stable, simple trolley with shelves for handling boxes and crates of different sizes. A 10 mm shelf edge around the trolley keeps the cargo secure. Chassis of 22 mm black powder-coated tubing. Max. load: 300 kg. Max. load per shelf: 100 kg. Four swivel wheels with grey rubber tyres measuring 125x30 mm, ball bearing hubs.

Art. no.	Shelves	Shelf dim.	Length	Width	Height
28150632	3	800x600	850	640	1460
28152632	3	1200x600	1250	640	1460

This trolley is part of our Wheely line.



SHELF TROLLEY BLACK – 4 SHELVES

Stable, simple trolley with shelves for handling boxes and crates of different sizes. A 10 mm shelf edge around the trolley keeps the cargo secure. Chassis of 22 mm black powder-coated tubing. Max. load: 300 kg. Max. load per shelf: 100 kg. Four swivel wheels with grey rubber tyres measuring 125x30 mm, ball bearing hubs.

Art. no.	Shelves	Shelf dim.	Length	Width	Height
28150642	4	800x600	850	640	1460
28152642	4	1200x600	1250	640	1460

This trolley is part of our Wheely line.





Model 24



SHELF TROLLEY SERIES 300

Two fixed wheels and two swivel wheels ensure optimum driving stability. Slightly larger sized wheels combined with a sturdy chassis make this trolley easy to drive even with heavy loads. Lower shelf is recessed in the frame profile. Max. load: 300 kg. Max. load, lower shelf: 300 kg. Max. load, upper shelves: 100 kg. Two fixed wheels and two swivel wheels with black rubber tyres measuring 160x40 mm, roller bearing hubs.

Model 22 – low ends, 2 shelves

Model 24 – high ends, 4 shelves

Model 22

Art. no.	Shelves	Shelf dim.	Length	Width	Height
25220623	2	800x600	990	650	1030
25221623	2	1000x600	1190	650	1030
25222623	2	1200x600	1390	650	1030
25224623	2	1400x600	1590	650	1030
25226623	2	1600x600	1790	650	1030

Model 22



Extra shelves models 22 and 24

Art. no.	Shelf dim.
12252306	800x600
12252316	1000x600
12252326	1200x600
12252346	1400x600
12252366	1600x600

Model 24

Art. no.	Shelves	Shelf dim.	Length	Width	Height
25240643	4	800x600	990	650	1690
25241643	4	1000x600	1190	650	1690
25242643	4	1200x600	1390	650	1690
25244643	4	1400x600	1590	650	1690
25246643	4	1600x600	1790	650	1690



Model 11



SHELF TROLLEY SERIES 300

A support wheel system (two wheels positioned centrally underneath the trolley) combined with four swivel wheels makes this trolley stable and easy to drive. Lower shelf is recessed in the frame profile. Max. load: 300 kg. Max. load, lower shelf: 300 kg. Max. load, upper shelves: 100 kg. Two centrally positioned wheels with grey elastic rubber tyres measuring 200x48 mm, ball bearing hubs. Four swivel wheels with grey rubber tyres measuring 125x32 mm, ball bearing hubs and safety guard. Delivered ready-assembled.

Model 11 – low ends, 2 shelves

Model 12 – high ends, 4 shelves

Model 11

Art. no.	Shelves	Shelf dim.	Length	Width	Height
15111424	2	1000x425	1180	460	1120
15112424	2	1200x425	1380	460	1120
15114424	2	1400x425	1580	460	1120
15116424	2	1600x425	1780	460	1120

Model 12



Extra shelves models 11 and 12

Art. no.	Shelf dim.
12252314	1000x425
12252324	1200x425
12252344	1400x425
12252364	1600x425

Model 12

Art. no.	Shelves	Shelf dim.	Length	Width	Height
15121444	4	1000x425	1180	460	1650
15122444	4	1200x425	1380	460	1650
15124444	4	1400x425	1580	460	1650
15126444	4	1600x425	1780	460	1650

ACCESSORIES – SERIES 300 SHELF TROLLEYS

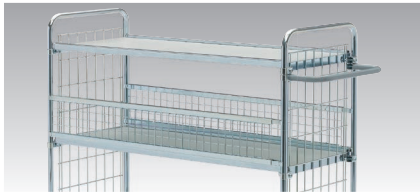

GRID RAIL

Easy to mount and dismantle. Mesh size: 30x30 mm. Height: 161 mm.

Art. no.	For shelf length
12212163	800 mm
12212165	1000 mm
12212168	1200 mm
12212169	1400 mm
12212170	1600 mm



SIDE GRID

Easy to mount and dismantle. Mesh size: 65x50 mm. Height 620 mm. Two grids are needed for trolleys with high ends.

Art. no.	For shelf length
12212142	800 mm
12212145	1000 mm
12212148	1200 mm
12212149	1400 mm
12212150	1600 mm



MEMO BOARD

With document clip. Type 1 mounted with clips, type 2 mounted with adjustable holder. Pen tray at top. Portrait A4.

Art. no.	Description
12200220	Type 1 with clip
12212220	Type 2 with adjustable holder



BASKET

For mounting on end. Mesh size at base 25x25 mm, open corners and 25x85 mm at end.

Art. no.	Dimensions
12200245	150x330x180 mm



SHELF PARTITION

Easy to move and remove. Wire distance 34 mm. Cannot be mounted on chassis shelf.

Art. no.	Dimensions	For model
12200104	400x220	11 & 12
12200106	600x220	22 & 24



STEPS

Supplementary handles are mounted at the same time, which can also be used as hand rails. These steps facilitate picking up to a height of 2.5 m. They automatically return to folded position when you step off. Only compatible with models 11 & 12. Only available when ordering new trolleys.

Art. no.	Height
12200036	600 mm



PROTECTIVE EDGING STRIP

A protective edging strip for mounting on trolleys. Also prevents trolleys from hooking onto each other. The strip is 33 mm high and increases the trolley width by 25 mm per side.

Art. no.	For shelf length
12253200	800 mm
12253210	1000 mm
12253220	1200 mm
12253240	1400 mm
12253260	1600 mm



TRUCK FORK GUIDE

For handling trolleys from long side. Please specify distance between the truck forks and the forks' height at highest point when ordering.

Art. no.
12253301



SUPPORT WHEEL SYSTEM

Two fixed wheels in the centre and two swivel wheels at either end. Optimises trolley's driving properties. For trolleys measuring 1000x600 mm and larger. Only available when ordering new trolleys.

Art. no.	Wheel size
12200363	160x40 mm



Model 25					
Art. no.	Shelves	Shelf dim.	Length	Width	Height
25250525	2	800x520	1000	570	1180
25251525	2	1000x520	1200	570	1180
25252525	2	1200x520	1400	570	1180
25250625	2	800x600	1000	650	1180
25251625	2	1000x600	1200	650	1180
25252625	2	1200x600	1400	650	1180
25254625	2	1400x600	1600	650	1180
25256625	2	1600x600	1800	650	1180
25251725	2	1000x700	1200	750	1180
25252725	2	1200x700	1400	750	1180
25254725	2	1400x700	1600	750	1180
25256725	2	1600x700	1800	750	1180
25252825	2	1200x800	1400	850	1180
25254825	2	1400x800	1600	850	1180
25256825	2	1600x800	1800	850	1180

SHELF TROLLEY SERIES 400

Slightly larger sized wheels combined with a sturdy chassis make this trolley easy to drive even with heavy loads. Each end panel has four sturdy uprights. The ends and shelves are reinforced to withstand loads up to 500 kg. Shelves reinforced with shelf supports. Max. load: 500 kg. Max. load, lower shelf: 500 kg. Max. load, upper shelves: 150 kg. Two fixed wheels and two swivel wheels with black rubber tyres measuring 200x50 mm, roller bearing hubs.

Model 25 – low ends, 2 shelves

Model 27 – high ends, 3 shelves

Model 27					
Art. no.	Shelves	Shelf dim.	Length	Width	Height
25270535	3	800x520	1000	570	1860
25271535	3	1000x520	1200	570	1860
25272535	3	1200x520	1400	570	1860
25270635	3	800x600	1000	650	1860
25271635	3	1000x600	1200	650	1860
25272635	3	1200x600	1400	650	1860
25274635	3	1400x600	1600	650	1860
25276635	3	1600x600	1800	650	1860
25271735	3	1000x700	1200	750	1860
25272735	3	1200x700	1400	750	1860
25274735	3	1400x700	1600	750	1860
25276735	3	1600x700	1800	750	1860
25272835	3	1200x800	1400	850	1860
25274835	3	1400x800	1600	850	1860
25276835	3	1600x800	1800	850	1860

Extra shelves, models 25 and 27	
Art. no.	Shelf dim.
12252405	800x520
12252415	1000x520
12252425	1200x520
12252406	800x600
12252416	1000x600
12252426	1200x600
12252446	1400x600
12252466	1600x600
12252417	1000x700
12252427	1200x700
12252447	1400x700
12252467	1600x700
12252428	1200x800
12252448	1400x800
12252468	1600x800

ACCESSORIES – SERIES 400 SHELF TROLLEYS

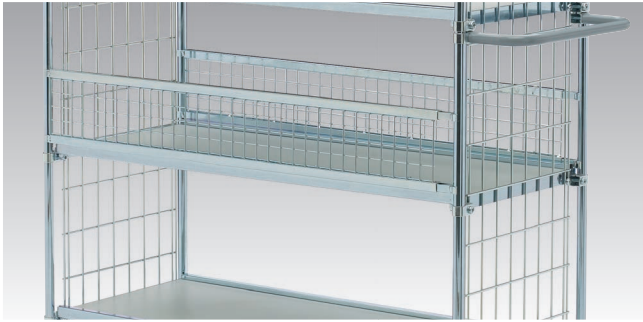

GRID RAIL

Easy to mount and dismantle. Mesh size: 30x30 mm. Height: 161 mm.

Art. no.	For shelf length
12212163	800 mm
12212165	1000 mm
12212168	1200 mm
12212169	1400 mm
12212170	1600 mm

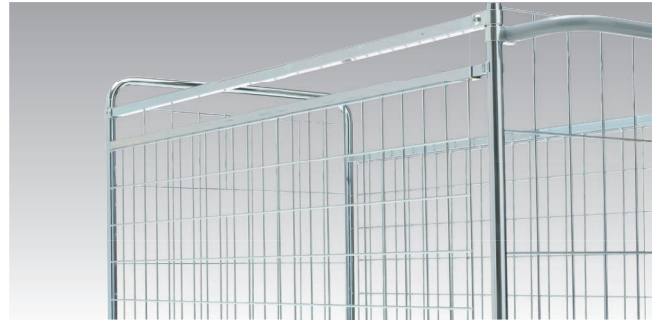

SIDE GRID

Easy to mount and dismantle. Mesh size: 65x50 mm. Height: 620 mm. Two grids are needed for trolleys with high ends.

Art. no.	For shelf length
12232142	800 mm
12212145	1000 mm
12212148	1200 mm
12212149	1400 mm
12212150	1600 mm



END GRID

Made of 7 mm steel bars, c-c distance 75 mm. For mounting with clips on inner uprights. Two grids are needed for trolleys with high ends.

Art. no.	For shelf length	Dimensions
12251546	520 and 600	420x650
12251547	700	600x650
12251548	800	700x650



BASKET

For mounting on end. Mesh size at base 25x25 mm, open corners and 25x85 mm at end.

Art. no.	Dimensions
12200245	150x330x180 mm

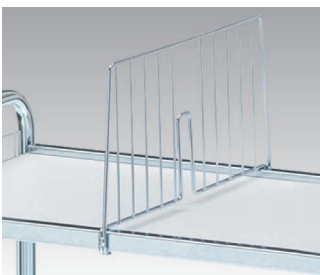

SHELF PARTITION

Easy to move and remove. Wire distance 34 mm. Cannot be mounted on chassis shelf. Fits trolleys with width of 600 mm.

Art. no.	Dimensions
12200106	600x220



MEMO BOARD

With document clip. Type 1 mounted with clips, type 2 mounted with adjustable holder. Pen tray at top. Portrait A4.

Art. no.	Description
12200220	Type 1 with clip
12212220	Type 2 with adjustable holder

ACCESSORIES – SERIES 400 SHELF TROLLEYS



PROTECTIVE EDGING STRIP

A protective edging strip for mounting on trolleys. Also prevents trolleys from hooking onto each other. The strip is 33 mm high and increases the trolley width by 25 mm per side.

Art. no.	For shelf length
12253200	800 mm
12253210	1000 mm
12253220	1200 mm
12253240	1400 mm
12253260	1600 mm



SUPPORT WHEEL SYSTEM

Two fixed wheels in the centre and two swivel wheels on either side. Optimises trolley's driving properties. For trolleys measuring 1000x600 mm and larger. Only available when ordering new trolleys.

Art. no.	Wheel size
12200364	200x50 mm

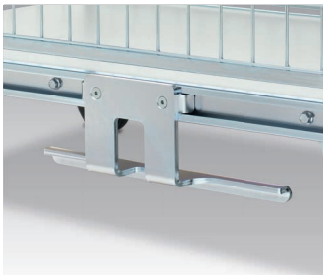

TRUCK FORK GUIDE

For handling trolleys from long side. Please specify distance between the truck forks and the forks' height at highest point when ordering.

Art. no.
12253301



STEPS

These steps facilitate picking up to a height of 2.5 m. They automatically return to folded position when you step off. Only available when ordering new trolleys.

Art. no.	Height
12200035	600 mm



TOW BAR

A device for linking together several trolleys. Folds upwards. Normally mounted on the end of the trolley with the fixed wheels. Hole diameter: 23 mm, length: 470 mm.

Art. no.
12253320



TOW HOOK

The coupling latch is 22 mm in diameter, and has a safety catch that prevents the tow bar from disconnecting. The tow hook is usually mounted on the end of the trolley with the swivel wheels.

Art. no.
12253321

EASY PICKING FROM HIGH UP

STEP TROLLEYS

Trolleys with easy-to-use pull-out steps that automatically return to folded position. The steps extend 60 cm above floor level, facilitating picking up to a height of 2.5 m. Shelf edges keep the cargo firmly in place. The chassis is made of 22 mm shiny zinc-coated tubing. Hard-wearing 12 mm shelves, reversible or detachable, with a light grey laminate finish.



STEP TROLLEY SERIES 100

Shiny zinc-coated shelf edge profiles 25x20 mm. Max. load: 200 kg. Max. load, shelves: 100 kg. Four swivel wheels with grey rubber tyres measuring 125x32 mm, ball bearing hubs and safety guard.

STEP TROLLEY SERIES 200

A support wheel system (two wheels positioned centrally underneath the trolley) makes the trolley easy to manoeuvre and turn, even with a heavy load. Shelf profile of 22 mm round, shiny zinc-coated tubing. Max. load: 300 kg. Max. load, shelves: 150 kg. Three or four swivel wheels with grey rubber tyres measuring 125x32 mm, ball bearing hubs and safety guard. Two centrally positioned wheels with black elastic rubber tyres measuring 200x50 mm, roller bearing hubs.

Art. no.	Shelves	Shelf dim.	Length	Width	Height
24113222	2	620x425	890	460	1120
24113322	2	750x425	1020	460	1120
24113522	2	1000x425	1270	460	1120
24113232	3	620x425	890	460	1120
24113332	3	750x425	1020	460	1120
24113532	3	1000x425	1270	460	1120
24113242	4	620x425	890	460	1585
24113342	4	750x425	1020	460	1585
24113542	4	1000x425	1270	460	1585

Art. no.	Shelves	Shelf dim.	Length	Width	Height
24123224	2	850x520	1130	520	1110
24123324	2	850x620	1130	620	1110
24123624	2	1250x620	1530	620	1110
24123234	3	850x520	1130	520	1110
24123334	3	850x620	1130	620	1110
24123634	3	1250x620	1530	620	1110

Extra shelves, series 100

Art. no.	Shelf dim.
12210210	620x425
12210310	750x425
12210510	1000x425

End grid mesh size 100x50 mm

Art. no.	Height
12200140	600 mm
12200144	800 mm

ACCESSORIES – SERIES 100 & 200 STEP TROLLEYS



GRID RAIL

Easy to mount and dismantle.
Mesh size: 30x30 mm. Height: 161 mm.
Only fits series 100.

Art. no.	For shelf length
12212162	750 mm
12212165	1000 mm



BASKET

For mounting on end. Mesh size at base 25x25 mm, open corners and 25x85 mm at end.

Art. no.	Dimensions
12200245	150x330x180 mm



MEMO BOARD

With document clip. Type 1 mounted with clips, type 2 mounted with adjustable holder. Pen tray at top. Portrait A4.



Art. no.	Description
12200220	Type 1 with clip
12212220	Type 2 with adjustable holder



PEN TRAY

Two models.

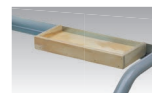

Art. no.	Description
12200221	Single, 180x80 mm
12200225	Double, 310x80 mm

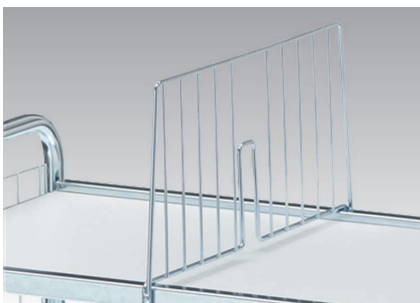

SHELF PARTITION

Easy to move and remove. Wire distance: 34 mm.
Only fits series 100.

Art. no.	Dimensions
12200104	420x220



BOX

Pulls out. Can be mounted on right or left side.
Only fits series 100.

Art. no.	Dimensions
12200440	370x150x100



SAFETY WHEELS

Protects trolleys, shelves and walls from damage. Set of four wheels for mounting on corner uprights. Only compatible with series 100. Only available when ordering new trolleys.

Art. no.
12212010

FOR STACKING GOODS IN NARROW SPACES

PLATFORM TROLLEYS

The shelf dimensions are adapted to standard boxes (600x400 mm). The chassis is made of 22 mm shiny zinc-coated tubing. Hard-wearing 12 mm shelves with a light grey laminate finish. Rubber-coated or powder-coated handles.

PLATFORM TROLLEY SERIES 100

Simple, stable and practical trolley suitable for moving single packages. Max. load: 200 kg. Four swivel wheels with grey rubber tyres measuring 125x32 mm, ball bearing hubs and safety guard. No shelf edging.

Art. no.	Shelves	Shelf dim.	Length	Width	Height
24112212	1	530x465	670	465	960
24112312	1	660x465	800	465	960
24112512	1	910x465	1050	465	960

End grid mesh size 100x50 mm	
Art. no.	
12200140	



PLATFORM TROLLEY SERIES 200

A support wheel system (two wheels positioned centrally underneath the trolley) makes the trolley easy to manoeuvre and turn, even with a heavy load. Max. load: 300 kg. Three or four swivel wheels with grey rubber tyres measuring 125x32 mm, ball bearing hubs and safety guard. Two centrally positioned wheels with black elastic rubber tyres measuring 200x50 mm, roller bearing hubs.

Art. no.	Shelves	Shelf dim.	Length	Width	Height	Handles
24125214	1	850x520	960	520	950	Horizontal
24125314	1	850x620	960	620	950	Horizontal
24125614	1	1250x620	1350	620	950	Horizontal
24121214	1	850x520	1130	520	1110	Vertical
24121314	1	850x620	1130	620	1110	Vertical
24121614	1	1250x620	1530	620	1110	Vertical

End grid mesh size 100x50 mm	
Art. no.	Height
12200140	600 mm
12200144	800 mm



PLATFORM TROLLEY SERIES 300

Slightly larger sized wheels combined with a sturdy chassis make this trolley easy to drive even with heavy loads. Equipped with an end grid as standard. The shelf is recessed in the frame profile. Detachable tubular frame on front. Max. load: 300 kg. Two fixed wheels and two swivel wheels with black rubber tyres measuring 160x40 mm, roller bearing hubs.



Art. no.	Shelves	Shelf dim.	Length	Width	Height
25510613	1	800x600	990	650	1030
25511613	1	1000x600	1190	650	1030
25512613	1	1200x600	1390	650	1030
25514613	1	1400x600	1590	650	1030
25516613	1	1600x600	1790	650	1030



PLATFORM TROLLEY SERIES 400

Slightly larger sized wheels combined with a sturdy chassis make this trolley easy to drive even with heavy loads. Each end panel has four sturdy uprights. The shelf is recessed in the frame profile. The ends are reinforced to withstand loads up to 500 kg. Two fixed wheels and two swivel wheels with black rubber tyres measuring 200x50 mm, roller bearing hubs.

Model 54 – one end panel, detachable tubular frame on front
Model 55 – two end panels

End grid

Art. no.	For shelf length	Dimensions
12251546	520 and 600	420x650
12251547	700	600x650
12251548	800	700x650

Made of 7 mm steel bars, c-c distance 75 mm. For mounting with clips on inner uprights. Two grids are needed for trolleys with high ends.

Model 54					
Art. no.	Shelves	Shelf dim.	Length	Width	Height
25540515	1	800x520	1000	570	1180
25541515	1	1000x520	1200	570	1180
25542515	1	1200x520	1400	570	1180
25540615	1	800x600	1000	650	1180
25541615	1	1000x600	1200	650	1180
25542615	1	1200x600	1400	650	1180
25544615	1	1400x600	1600	650	1180
25546615	1	1600x600	1800	650	1180
25541715	1	1000x700	1200	750	1180
25542715	1	1200x700	1400	750	1180
25544715	1	1400x700	1600	750	1180
25546715	1	1600x700	1800	750	1180
25549715	1	2000x700	2200	750	1180
25541815	1	1000x800	1200	850	1180
25542815	1	1200x800	1400	850	1180
25544815	1	1400x800	1600	850	1180
25546815	1	1600x800	1800	850	1180
25549815	1	2000x800	2200	850	1180

Model 55					
Art. no.	Shelves	Shelf dim.	Length	Width	Height
25550515	1	800x520	1000	570	1180
25551515	1	1000x520	1200	570	1180
25552515	1	1200x520	1400	570	1180
25550615	1	800x600	1000	650	1180
25551615	1	1000x600	1200	650	1180
25552615	1	1200x600	1400	650	1180
25554615	1	1400x600	1600	650	1180
25556615	1	1600x600	1800	650	1180
25551715	1	1000x700	1200	750	1180
25552715	1	1200x700	1400	750	1180
25554715	1	1400x700	1600	750	1180
25556715	1	1600x700	1800	750	1180
25559715	1	2000x700	2200	750	1180
25551815	1	1000x800	1200	850	1180
25552815	1	1200x800	1400	850	1180
25554815	1	1400x800	1600	850	1180
25556815	1	1600x800	1800	850	1180
25559815	1	2000x800	2200	850	1180

ACCESSORIES – PLATFORM TROLLEYS

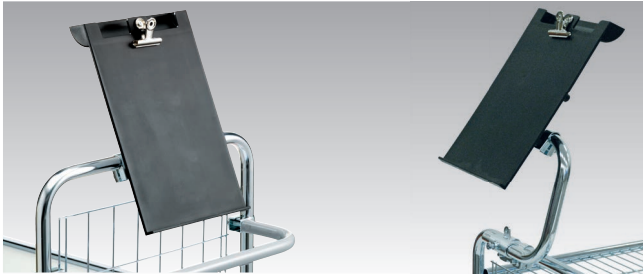

MEMO BOARD

With document clip. Type 1 mounted with clips, type 2 mounted with adjustable holder. Pen tray at top. Portrait A4.

Art. no.	Description
12200220	Type 1 with clip
12212220	Type 2 with adjustable holder



BASKET

For mounting on end. Mesh size at base 25x25 mm, open corners and 25x85 mm at end.

Art. no.	Dimensions
12200245	150x330x180 mm



PROTECTIVE EDGING STRIP

A protective edging strip for mounting on trolleys. to protect them and prevent them from hooking onto each other. The strip is 33 mm and increases the trolley width by 25 mm per side. Compatible with trolleys from series 300 and 400.

Art. no.	For shelf length
12253200	800 mm
12253210	1000 mm
12253220	1200 mm
12253240	1400 mm
12253260	1600 mm



PEN TRAY

Two models. Only compatible with series 200 and 400.

Art. no.	Description
12200221	Single, 180x80 mm
12200225	Double, 310x80 mm

FOR EASY ACCESS

PARCEL TROLLEYS

Ideal for transporting packages etc. Chassis made of 22 mm shiny zinc-coated tubing. Hard-wearing 12 mm shelves with a light grey laminate finish. Side grids can be detached or opened, making the trolley easy to adapt. Powder-coated, continuously height-adjustable handles.



PARCEL TROLLEY SERIES 100

Detachable grids on long sides. Grids are made of shiny zinc-coated square tubing and are fitted with spring action fasteners on the end uprights. Mesh size: 50x82 mm. Height: 620 mm. Max. load: 100 kg. Four swivel wheels with grey elastic rubber tyres measuring 125x32 mm, ball bearing hubs and safety guard.

Art. no.	Shelves	Shelf dim.	Length	Width	Height
24118212	1	620x425	800	460	1120
24118312	1	750x425	930	460	1120
24118512	1	1000x425	1180	460	1120
24118612	1	1200x425	1380	460	1120

PARCEL TROLLEY SERIES 300

Chassis in 22 mm shiny zinc-coated tubing. Detachable grids on long sides. Grids are made of shiny zinc-coated square tubing and are fitted with spring action fasteners on the end uprights Mesh size: 50x82 mm. Height: 620 mm. The shelf is recessed in the frame profile. Max. load: 300 kg. Two fixed wheels and two swivel wheels with black rubber tyres measuring 160x40 mm, roller bearing hubs.

Model 82 – with long ends

Model 84 – with high ends

Model 82

Art. no.	Shelves	Shelf dim.	Length	Width	Height
25820613	1	800x600	990	650	1030
25821613	1	1000x600	1190	650	1030
25822613	1	1200x600	1390	650	1030
25824613	1	1400x600	1590	650	1030
25826613	1	1600x600	1790	650	1030

Model 84

Art. no.	Shelves	Shelf dim.	Length	Width	Height
25840613	1	800x600	990	650	1690
25841613	1	1000x600	1190	650	1690
25842613	1	1200x600	1390	650	1690
25844613	1	1400x600	1590	650	1690
25846613	1	1600x600	1790	650	1690



Model 84



Model 82



PARCEL TROLLEY SERIES 400

Slightly larger sized wheels combined with a sturdy chassis make this trolley easy to drive even with heavy loads. Each end panel has four sturdy uprights. The shelf is recessed in the frame profile. The ends are reinforced to withstand loads up to 500 kg. Side gates are easily opened. Max. load: 500 kg. Two fixed wheels and two swivel wheels with black rubber tyres measuring 200x50 mm, roller bearing hubs. Delivered ready-assembled.

Art. no.	Shelves	Shelf dim.	Length	Width	Height
15861615	1	1000x600	1200	650	1180
15862615	1	1200x600	1400	650	1180
15864615	1	1400x600	1600	650	1180
15866615	1	1600x600	1800	650	1180
15861715	1	1000x700	1200	750	1180
15862715	1	1200x700	1400	750	1180
15864715	1	1400x700	1600	750	1180
15866715	1	1600x700	1800	750	1180
15862815	1	1200x800	1400	850	1180
15864815	1	1400x800	1600	850	1180
15866815	1	1600x800	1800	850	1180



ACCESSORIES – PARCEL TROLLEYS



MEMO BOARD

With document clip. Type 1 mounted with clips, type 2 mounted with adjustable holder. Pen tray at top. Portrait A4.



Art. no.	Description
12200220	Type 1 with clip
12212220	Type 2 with adjustable holder



BASKET

For mounting on end. Mesh size at base 25x25 mm, open corners and 25x85 mm at end.

Art. no.	Dimensions
12200245	150x330x180 mm



PEN TRAY

Two models. Not compatible with series 300.

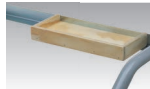

Art. no.	Description
12200221	Single, 180x80 mm
12200225	Double, 310x80 mm



SAFETY WHEELS

Protects trolleys, shelves and walls from damage. Set of four wheels for mounting on corner uprights. Only available when ordering new trolleys. Only fits series 100.

Art. no.
12212010



PROTECTIVE EDGING STRIP

A protective edging strip for mounting on trolleys. to protect them and prevent them from hooking onto each other. The strip is 33 mm and increases the trolley width by 25 mm per side. Compatible with trolleys from series 300 and 400.

Art. no.	For shelf length
12253200	800 mm
12253210	1000 mm
12253220	1200 mm
12253240	1400 mm
12253260	1600 mm



SUPPORT WHEEL SYSTEM

Two fixed wheels in the centre and two swivel wheels on either side. Optimises trolley's driving properties. For trolleys measuring 1000x600 mm and larger. Only available when ordering new trolleys.

Art. no.	Wheel size	Compatible with trolley series
12200363	160x40 mm	300
12200364	200x50 mm	400

ALTERNATIVE WHEELS

If you order a new trolley with a wheel kit that is not original, the article number that starts with 12 applies to the whole set of wheels (accessory). If you only order wheels as spare parts, the article number beginning with 07 applies to each individual wheel.

ACCESSORIES AND SPARE PARTS – FOR SERIES 100



SWIVEL WHEELS
With rubber tyres and ball bearing hubs, 150x32 mm.

Art. no.	Part no.
12200318	07011311



SWIVEL WHEELS
With polyurethane foam tyres and ball bearing hubs, 150x30 mm.

Art. no.	Part no.
12200321	07011325



WHEELS WITH DOUBLE BRAKES
Locks the rotating action of both the wheel and the bracket. For mounting on two 125 mm wheels.

Art. no.	Part no.
12200302	07011305



WHEELS WITH DISCONNECTABLE DIRECTIONAL LOCK
For mounting on a swivel wheel, locks the rotating action of the bracket.

Art. no.	Part no.
12200312	07011309

ACCESSORIES AND SPARE PARTS – FOR SERIES 200



SOLID RUBBER WHEELS
With roller bearing hubs, 200x50 mm. Grey rubber tyres for delicate floors.

Art. no.	Part no.
12222012	07013437



NYLON WHEELS
With polyurethane tyres and ball bearing hubs, 200x46 mm. An easy-rolling wheel for tough workshop environments, with extra durable tyres.

Art. no.	Part no.
12222016	07016020



ELASTIC WHEELS
With ball bearing hubs, 200x46 mm. An exclusive wheel that rolls easily, even with heavy loads. Grey elastic rubber tyres for delicate floors.

Art. no.	Part no.
12222014	07013470

ACCESSORIES AND SPARE PARTS – FOR SERIES 300



GREY WHEELS

With rubber tyres for delicate floors,
200x50 mm.

Art. no.	Part no.
12200323	07012437 swivel 07013437 fixed



WHEELS WITH DOUBLE BRAKES

Locks the rotating action of both the
wheel and the bracket, 160x40 mm.
For mounting on two wheels.

Art. no.	Part no.
12200303	07011422



PNEUMATIC WHEELS

Ideal for use on uneven surfaces. Two
swivel wheels and two fixed wheels
210x65 mm, with roller bearings.

Art. no.	Part no.
12200307	07019023 swivel 07019024 fixed



NYLON WHEELS

Extra durable tyres for tough environments.
Polyurethane tyres and ball bearing hubs,
200x46 mm.

Art. no.	Part no.
12200326	07011454 swivel 07012454 fixed



ELASTIC WHEELS

Wheels with quiet, smooth operation.
Grey rubber tyres with ball bearing hubs,
200x46 mm.

Art. no.	Part no.
12200329	07011448 swivel 07012448 fixed

ACCESSORIES AND SPARE PARTS – FOR SERIES 400



GREY WHEELS

With rubber tyres for delicate floors,
200x50 mm.

Art. no.	Part no.
12200324	07012437 swivel 07013437 fixed



WHEELS WITH DOUBLE BRAKES

Locks the rotating action of both the
wheel and the bracket, 160x40 mm.
For mounting on two wheels.

Art. no.	Part no.
12200304	07011435



PNEUMATIC WHEELS

Ideal for use on uneven surfaces. Two
swivel wheels and two fixed wheels
210x65 mm, with roller bearings.

Art. no.	Part no.
12200309	07019023 swivel 07019024 fixed



NYLON WHEELS

Extra durable tyres for tough environments.
Polyurethane tyres and ball bearing hubs,
200x46 mm.

Art. no.	Part no.
12200327	07011454 swivel 07012454 fixed



ELASTIC WHEELS

Wheels with quiet, smooth operation.
Grey rubber tyres with ball bearing hubs,
200x46 mm.

Art. no.	Part no.
12200325	07011448 swivel 07012448 fixed

A FLEXIBLE SOLUTION FOR SMALL GOODS

BOX TROLLEYS AND DOLLIES

Flexible and adjustable trolleys that can easily be adjusted to the correct working height. The trolleys are available with inclinable shelves or a guide rail system. Four swivel wheels allow them to roll in all directions. The dollies are available with two fixed wheels and two swivel wheels for optimum driving stability. The shelf dimensions are adapted to standard boxes (600x400 mm). The chassis is made of 22 mm shiny zinc-coated tubing (19 mm for box dollies). Hard-wearing 12 mm shelves with a light grey laminate finish.



FULL PALLET DOLLY

Dolly with four swivel wheels for easy and flexible handling of pallets. Can be fitted with different kinds of wheels and brakes. Suitable for use in Taxi trains. Max. load: 600 kg.



HALF PALLET DOLLY

Dolly with four swivel wheels for easy and flexible handling of half pallets. Can be fitted with different kinds of wheels and brakes. Suitable for use in Taxi trains. Max. load: 300 kg.

Art. no.	Max pallstorlek
14902122	1250x840 mm

Art. no.	Max pallstorlek
14902123	840x620 mm



PALLET DOLLY, FULL AND HALF PALLET

Max load 500 kg. Four swivel wheels or two swivel wheels and two fixed wheels. Black nylon 100x35 mm with slide bearing hubs or blue polyurethane 100x35 mm with ball bearing hubs. Delivered ready-assembled.

Art. no.	Length	Width	Height	Wheels
14189816	1042	815	140	4 swivel wheels black
14189817	1042	815	140	2 fixed wheels, 2 swivel wheels black
14189916	1042	815	140	4 swivel wheels blue
14189917	1042	815	140	2 fixed wheels, 2 swivel wheels blue

Art. no.	Length	Width	Height	Wheels
14189806	815	575	140	4 swivel wheels black
14189807	815	575	140	2 fixed wheels, 2 swivel wheels black
14189906	815	575	140	4 swivel wheels blue
14189907	815	575	140	2 fixed wheels, 2 swivel wheels blue

SMALL STEEL TUBE DOLLY

Stackable steel tube dolly with a sturdy tube construction with round edges. A tow bar can easily be connected to the dolly (see page 63). Ideal for handling heavy goods, for example in plastic boxes or on half pallets. Max. load: 400 kg. Four swivel wheels or two swivel wheels and two fixed wheels, with grey elastic rubber tyres measuring 100x35 mm, ball bearing hubs. Height of 10 stacked dollies: approx. 1100 mm.

Art. no.	Length	Width	Height	Wheels
24185126	660	440	155	4 swivel wheels
24185127	660	440	155	2 fixed wheels, 2 swivel wheels

ACCESSORIES

Art. no.	Description
12200061	Tow bar for small dolly
12200062	Tow bar for large dolly



LARGE STEEL TUBE DOLLY

Stackable steel tube dolly with a sturdy tube construction with round edges. A tow bar can easily be connected to the dolly (see page 63). Ideal for handling heavy goods, for example in plastic boxes or on half pallets. Max. load: 400 kg. Four swivel wheels or two swivel wheels and two fixed wheels, with grey elastic rubber tyres measuring 100x35 mm, ball bearing hubs. Height of 10 stacked dollies: approx. 1100 mm.

Art. no.	Length	Width	Height	Wheels
24185226	650	410	150	4 swivel wheels
24185227	650	410	150	2 fixed wheels, 2 swivel wheels

SHEET METAL DOLLY

Sturdy construction. Ideal for handling heavy goods, for example in plastic boxes. Max. load: 300 kg. Four swivel wheels or two swivel wheels and two fixed wheels, with grey elastic rubber tyres measuring 100x35 mm, ball bearing hubs. Height of 10 stacked dollies: approx. 1100 mm.

Art. no.	Length	Width	Height	Wheels
24185226	650	410	150	4 swivel wheels
24185227	650	410	150	2 fixed wheels, 2 swivel wheels



LARGE WIRE DOLLY

Ideal for handling plastic boxes. Double wires form a frame that also provides an edge. 7 mm wire in frame. Max. load: 200 kg. Four swivel wheels with grey rubber tyres measuring 100x25 mm, slide bearing hubs. Height of 10 stacked dollies: approx. 1100 mm.

Art. no.	Length	Width	Height	Wheels
28183020	820	610	140	4 swivel wheels

This trolley is part of our Wheely line.



SMALL WIRE DOLLY

Ideal for handling plastic boxes. Double wires form a frame that also provides an edge. 6 mm wire in frame. Max. load: 200 kg. Four swivel wheels with grey rubber tyres measuring 100x25 mm, slide bearing hubs. Height of 10 stacked dollies: approx. 1100 mm.

Art. no.	Length	Width	Height	Wheels
28183010	620	410	140	4 swivel wheels

This trolley is part of our Wheely line.



BOX TROLLEY

This trolley has room for up to eight boxes. Distance between guide rails: 165 mm. Max. load: 200 kg. Four swivel wheels with grey rubber tyres measuring 125x32 mm, ball bearing hubs and safety guard.

Art. no.	Length	Width	Height
24119182	670	465	1585

ACCESSORIES

Art. no.	Description
12200302	Double brakes for two wheels
12200312	Directional lock for one wheel



BOX TROLLEY FLEX

The guide rails on the trolley are inclinable and continuously adjustable. They can also be equipped with shelves. Guide rails and shelves must be ordered separately. Max. load: 200 kg. Four swivel wheels with grey rubber tyres measuring 125x32 mm, ball bearing hubs and safety guard.

Art. no.	Length	Width	Height
24119172	670	463	1785

ACCESSORIES

Art. no.	Description
12219130	Pair of guide rails
12219135	Pair of guide rails with box restrainer
12219137	Shelf, 600x400 mm
12200302	Double braking system



ASSEMBLY TROLLEY

The two upper levels can be angled in both directions in fixed positions (10, 20 or 30°). Delivered with steel frames suitable for boxes. Laminated shelves must be ordered separately. Max. load: 100 kg. Four swivel wheels with grey rubber tyres measuring 125x32 mm, ball bearing hubs and safety guard.

Art. no.	Length	Width	Height
24119162	740	430	1165

ACCESSORIES

Art. no.	Description
12219137	Shelf, 600x400 mm

EXTRA HIGH PLATFORM TROLLEY

Available for 600x400 mm boxes. Puts the boxes at an ideal height for ergonomic lifting and comfortable assembly around the workplace. Shelf dimensions: 620x425 mm. Shelf height is adjustable up to 460 mm. Handle made of 22 mm shiny zinc-coated tubing with plastic-coated grips. Max. load: 100 kg. Four swivel wheels with grey rubber tyres measuring 125x32 mm, ball bearing hubs and safety guard.



Art. no.	Length	Width	Height
24111212	760	460	960

ACCESSORIES	
Art. no.	Description
12200302	Double brakes



DOLLY WITH HANDLE

The handle can be mounted on either of the short sides, and facilitates moving of the dolly. Max. load: 300 kg. Two swivel wheels and two fixed wheels with grey elastic rubber tyres 100x35 mm and ball bearing hubs.

Art. no.	Length	Width	Height	Wheels
24186827	750	410	940	2 fixed wheels, 2 swivel wheels



EXTRA HIGH DOLLY

Available for 600x400 mm or 800x600 mm boxes. Height of boxes is ideal for lifting and comfortable assembly in the workplace. Max. load 300 kg. Four swivel wheels with grey elastic rubber tyres 100x35 mm, ball bearing hubs.

Art. no.	Length	Width	Height
24185826	660	440	460
24185836	860	640	460

LEAVE YOUR HANDS FREE

OFFICE TROLLEYS

Our smart office trolleys make your work easier, faster and more ergonomic. The trolleys are designed to be as practical, flexible and functional as possible to meet a complete range of needs throughout the office environment.



FILE TROLLEY SHORT

Chassis made of 19 mm chrome tubing with rounded edges. Hard-wearing wood laminate shelves. Height between shelves 400 mm. Max. load: 75 kg. File shelf can take a maximum load of 30 kg and has room for 16 files. Two file supports included as standard. Four swivel wheels with grey rubber tyres 100x25 mm, slide bearing hubs.

Art. no.	Laminate	Shelves	Shelf dim.	Length	Width	Height
28195430	Beech	2	500x290	550	340	840
28195440	Birch	2	500x290	550	340	840
28195450	Oak	2	500x290	550	340	840
28195460	Light grey	2	500x290	550	340	840
28195470	Cherry	2	500x290	550	340	840

ACCESSORIES	
Art. no.	Description
12200300	Brakes on four wheels

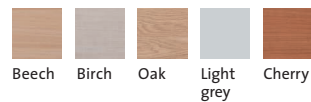

FILE TROLLEY LONG

Chassis made of 19 mm chrome tubing with rounded edges. Hard-wearing wood laminate shelves. Height between shelves 400 mm. Max. load: 75 kg. File shelf can take a maximum load of 30 kg and has room for 24 files. Two file supports included as standard. Four swivel wheels with grey rubber tyres 100x25 mm, slide bearing hubs.

Art. no.	Laminate	Shelves	Shelf dim.	Length	Width	Height
28195432	Beech	2	750x290	800	340	840
28195442	Birch	2	750x290	800	340	840
28195452	Oak	2	750x290	800	340	840
28195462	Light grey	2	750x290	800	340	840
28195472	Cherry	2	750x290	800	340	840

ACCESSORIES	
Art. no.	Description
12200300	Brakes on four wheels

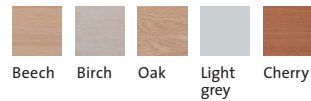

FILE TROLLEY SHORT WITH TOP SHELF

Chassis made of 19 mm chrome tubing with rounded edges. Hard-wearing wood laminate shelves. Height between shelves 400 mm. Max. load: 75 kg. File shelf can take a maximum load of 30 kg and has room for 16 files. Max. load top shelf: 15 kg. Two file supports included as standard. Four swivel wheels with grey rubber tyres 100x25 mm, slide bearing hubs.

Art. no.	Laminate	Shelves	Shelf dim.	Length	Width	Height
28195431	Beech	3	500x290	550	340	1060
28195441	Birch	3	500x290	550	340	1060
28195451	Oak	3	500x290	550	340	1060
28195461	Light grey	3	500x290	550	340	1060
28195471	Cherry	3	500x290	550	340	1060

ACCESSORIES	
Art. no.	Description
12200300	Brakes on four wheels

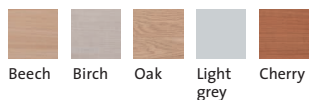

FILE TROLLEY LONG WITH TOP SHELF

Chassis made of 19 mm chrome tubing with rounded edges. Hard-wearing wood laminate shelves. Height between shelves 400 mm. Max. load: 75 kg. File shelf can take a maximum load of 30 kg and has room for 24 files. Max. load top shelf: 15 kg. Two file supports included as standard. Four swivel wheels with grey rubber tyres 100x25 mm, slide bearing hubs.

Art. no.	Laminate	Shelves	Shelf dim.	Length	Width	Height
28195433	Beech	3	750x290	800	340	1060
28195443	Birch	3	750x290	800	340	1060
28195453	Oak	3	750x290	800	340	1060
28195463	Light grey	3	750x290	800	340	1060
28195473	Cherry	3	750x290	800	340	1060

ACCESSORIES	
Art. no.	Description
12200300	Brakes on four wheels

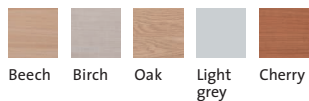

Sturdy load-bearing
wheels and guide wheels



FILING TROLLEY, BEECH, THREE FILE SHELVES

Chassis made of 22 mm chrome tubing with rounded edges. Hard-wearing wood laminate shelves. Thickness: 19 mm at back, 12 mm in shelf panel. One file support per shelf in standard version. *Available with sturdy load-bearing wheels and guide wheels centrally mounted underneath the trolley. This makes the trolley easy to turn even with a heavy load. (See small picture). Max. load: 150-250 kg depending on wheel system used. Four swivel wheels with grey rubber tyres 125x32 mm, ball bearing hubs and safety guard. The sturdier type of wheels are supplemented with two centrally mounted wheels with grey elastic rubber tyres 200x48 mm, ball bearing hubs.

Art. no.	Shelves	Shelf dim.	Length	Width	Height
24119452	3	725x300	900	460	1280
24119462	3	1005x300	1180	460	1280
24119465*	3	1005x300	1180	460	1340

ACCESSORIES

Art. no.	Description
12200402	Extra file support

Sturdy load-bearing
wheels and guide wheels



FILING TROLLEY, BEECH, TWO FILE SHELVES AND PRODUCT RESTING SHELF

Chassis made of 22 mm chrome tubing with rounded edges. Hard-wearing wood laminate shelves. Thickness: 19 mm at back, 12 mm in shelf panel. One file support per shelf in standard version. *Available with sturdy load-bearing wheels and guide wheels centrally mounted underneath the trolley. This makes the trolley easy to turn even with a heavy load. (See small picture). Max. load: 150-250 kg depending on wheel system used. Four swivel wheels with grey rubber tyres 125x32 mm, ball bearing hubs and safety guard. The sturdier wheels are supplemented with two centrally mounted wheels with grey elastic rubber tyres 200x48 mm, ball bearing hubs.

Art. no.	Shelves	Shelf dim.	Length	Width	Height
24119472	3	725x300	900	460	1280
24119482	3	1005x300	1180	460	1280
24119485*	3	1005x300	1180	460	1340

ACCESSORIES

Art. no.	Description
12200402	Extra file support



SHELF TROLLEY BLACK

Chassis made of 22 mm powder-coated tubing with rounded edges. Hard-wearing 12 mm shelves, reversible, with light grey laminate finish. Max. load: 100 kg and 35 kg per shelf. Four swivel wheels with grey rubber tyres measuring 100x25 mm, slide bearing hubs. Space for 7 or 12 files per shelf.

Art. no.	Shelves	Shelf dim.	Length	Width	Height	Miscellaneous
28190210	3	430x275	480	320	1130	Short
28190220	3	730x275	780	320	1130	Long

This trolley is part of our Wheely line.



FILE TROLLEY BLACK

Chassis made of 22 mm powder-coated tubing with rounded edges. Hard-wearing 12 mm shelves, reversible, with light grey laminate finish. Max. load: 100 kg and 35 kg per shelf. Four swivel wheels with grey rubber tyres measuring 100x25 mm, slide bearing hubs. Includes one file support per shelf. Space for 7 or 12 files per shelf.

Art. no.	Shelves	Shelf dim.	Length	Width	Height	Miscellaneous
28190211	3	430x275	480	320	1130	Short
28190221	3	730x275	780	320	1130	Long

This trolley is part of our Wheely line.



BASKET TROLLEY BLACK

Chassis made of 22 mm powder-coated tubing with rounded edges. Hard-wearing 12 mm shelves, reversible, with light grey laminate finish. Basket dimension 410x230x201 mm. Max. load: 100 kg and 35 kg per basket/shelf. Four swivel wheels with grey rubber tyres measuring 100x25 mm, slide bearing hubs.

Art. no.	Shelves	Shelf dim.	Length	Width	Height
28190215	3	430x275	480	320	1130

This trolley is part of our Wheely line.



Mobile table,
large

MOBILE TABLE, LARGE

Chassis made of 22 mm shiny zinc-coated tubing. Hard-wearing shelves with wood laminate or light grey laminate finish. Thickness: upper shelf 19 mm, lower shelf 12 mm. Max. load: 100 kg. Four swivel wheels with grey rubber tyres measuring 125x32 mm, ball bearing hubs and safety guard.

Art. no.	Laminate	Shelves	Tabletop	Lower shelf	Height
24173612	Beech	2	1200x600	750x420	900
24172612	Light grey	2	1200x600	750x420	900



Mobile table,
medium

MOBILE TABLE, MEDIUM

Chassis made of 22 mm shiny zinc-coated tubing. Hard-wearing shelves with wood laminate or light grey laminate finish. Thickness: upper shelf 19 mm, lower shelf 12 mm. Max. load: 100 kg. Four swivel wheels with grey rubber tyres measuring 125x32 mm, ball bearing hubs and safety guard.

Art. no.	Laminate	Shelves	Tabletop	Lower shelf	Height
24173312	Beech	2	820x600	750x420	900
24172312	Light grey	2	820x600	750x420	900



Mobile table,
small

MOBILE TABLE, SMALL

Chassis made of 22 mm shiny zinc-coated tubing. Hard-wearing shelves with wood laminate or light grey laminate finish. Thickness: upper shelf 19 mm, lower shelf 12 mm. Max. load: 50 kg. Four swivel wheels 100x25 mm, slide bearing hubs.

Art. no.	Laminate	Shelves	Tabletop	Lower shelf	Height
24173120	Beech	2	600x430	360x420	1060
24171120	Light grey	2	600x430	360x420	1060

ACCESSORIES – MOBILE TABLES



FILE SHELF / FILE SUPPORT

Only available with beech laminate finish. Space for 6 or 12 files.

Art. no.	Dimensions	Compatible with
12210124	385x300	Mobile table, small
12210324	726x300	Mobile table, medium and large
12200402		File support for Mobile Table small, medium and large

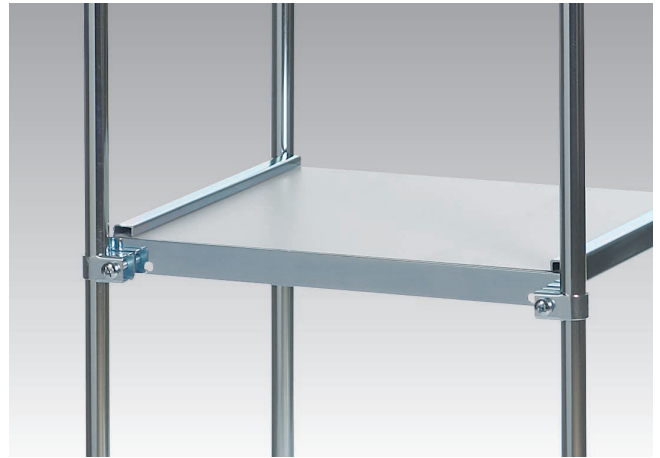

EXTRA SHELF

Laminated in grey or beech. Complete with mountings.

Art. no.	Laminate	Dimensions
12210310	Light grey	750x420
12210313	Beech	750x420
12210110	Light grey	360x420
12210111	Beech	360x420



BOX

Pulls out. Can be mounted on right or left side.

Art. no.	Dimensions
12200440	370x150x100

WHEEL BRAKE

Only applies when ordering new trolleys.

Art. no.	Compatible with
12200370	Mobile table, small

DOUBLE BRAKES

Only applies when ordering new trolleys.

Art. no.	Compatible with
12200372	Mobile table, medium and large



OFFICE TROLLEY EXCLUSIVE

Chassis made of 22 mm chrome tubing with rounded corners. End grids with 3 mm thick wire and mesh size 50x100 mm. Side grids with 2.5 mm thick wire and mesh size 35x35 mm. Handles made of 22 mm shiny zinc-coated tubing with plastic-coated grips. Chrome shelf edge profile 25x20 mm. Hard-wearing, reversible 12 mm thick shelves with light grey laminate finish. Shelves are continuously height-adjustable. Grid rail on upper shelf. Max. load: 200 kg. Four swivel wheels with grey rubber tyres measuring 125x32 mm, ball bearing hubs.

Art. no.	Shelves	Shelf dim.	Length	Width	Height
24119510	2	620x425	800	460	940



POST TROLLEY, LARGE

Chassis made of 22 mm shiny zinc-coated tubing with rounded corners. Handles made of 22 mm powder-coated tubing. Shiny zinc-coated shelf edge profile 25x20 mm. Hard-wearing 12 mm shelves with light grey laminate finish. Max. load: 200 kg. Max load per shelf: 100 kg. Max load, file shelf: 75 kg. Four swivel wheels with grey rubber tyres measuring 125x35 mm, ball bearing hubs, safety guard and four safety wheels. 15 folio files included as standard. Delivered ready-assembled.

Art. no.	Shelves	Shelf dim.	Length	Width	Height
14119500	2	750x425	930	460	1120

POST TROLLEY, SMALL

Chassis made of 22 mm shiny zinc-coated tubing with rounded corners. Handles made of 22 mm shiny zinc-coated tubing. Rubber-coated handles. Max. load: 50 kg. Max. load per shelf/basket: 10 kg. Max. load, chassis: 25 kg. Four swivel wheels with grey elastic rubber tyres measuring 100x25 mm, slide bearing hubs and safety guard. 10 folio files included as standard. A4 files also fit into trolley suspended crosswise. Delivered ready-assembled.

Art. no.	Length	Width	Height
14190110	640	400	1080

FOLIO FILES

Art. no.	Dimensions
12200110	370x240



MINI TROLLEY, TWO SHELVES

Chassis made of 22 mm shiny zinc-coated tubing. Rounded corners. Rubber-coated handles. Shelves are continuously height-adjustable. Hard-wearing 12 mm shelves with light grey laminate finish. Max. load: 50 kg. Per shelf: 10 kg. Chassis: 25 kg. Four swivel wheels with grey elastic rubber tyres measuring 100x25 mm, slide bearing hubs.

Art. no.	Shelf dim.	Length	Width	Height
24190120	410x350	650	360	1065



MINI TROLLEY, TWO BASKETS

Chassis made of 22 mm shiny zinc-coated tubing. Rounded corners. Rubber-coated handles. Baskets are continuously height-adjustable, dimensions 405x300x210 mm. Max. load: 50 kg. Per basket: 10 kg. Chassis: 25 kg. Four swivel wheels with grey rubber tyres measuring 100x25 mm, slide bearing hubs.

Art. no.	Basket dim.	Length	Width	Height
24190130	405x300x210	650	360	1065

MINI TROLLEY ONE SHELF, ONE BASKET

Chassis made of 22 mm shiny zinc-coated tubing. Rounded corners. Rubber-coated handles. Shelf and basket are continuously height-adjustable. Shelf thickness: 12 mm. Durable, light grey laminate finish. Basket dimensions: 405x300x210 mm. Max. load: 50 kg. Per shelf/basket: 10 kg. Chassis: 25 kg. Four swivel wheels with grey rubber tyres measuring 100x25 mm, slide bearing hubs.

Art. no.	Shelf dim.	Length	Width	Height
24190140	410x350	650	360	1065

ACCESSORIES

Art. no.	Description
12290011	Basket
12290010	Shelf
12200300	Brake





MINI TROLLEY BLACK, TWO SHELVES

End panel is equipped with handles made of 22 mm powder-coated tubing. Rounded corners. Shelves are continuously height-adjustable. Hard-wearing 12 mm shelves with light grey laminate finish. Max. load: 50 kg. Per shelf: 10 kg. Chassis: 25 kg. Four swivel wheels with grey elastic rubber tyres measuring 100x25 mm, slide bearing hubs.

Art. no.	Shelf dim.	Length	Width	Height
28190120	410x350	650	360	1065

This trolley is part of our Wheely line.



MINI TROLLEY BLACK, TWO BASKETS

End panel is equipped with handles made of 22 mm powder-coated tubing. Rounded corners. Baskets are continuously height-adjustable, dimensions 405x300x210 mm. Max. load: 50 kg. Per basket: 10 kg. Chassis: 25 kg. Four swivel wheels with grey elastic rubber tyres measuring 100x25 mm, slide bearing hubs.

Art. no.	Basket dim.	Length	Width	Height
28190130	405x300x210	650	360	1065

This trolley is part of our Wheely line.

MINI TROLLEY BLACK, ONE SHELF, ONE BASKET

End panel with handles made of 22 mm powder-coated tubing. Rounded corners. Shelf and basket are continuously height-adjustable. Shelf thickness: 12 mm. Durable with light grey laminate finish. Basket dimensions 405x300x210 mm. Max. load: 50 kg. Per shelf/basket: 10 kg. Chassis: 25 kg. Four swivel wheels with grey rubber tyres measuring 100x25 mm, slide bearing hubs.

Art. no.	Shelf dim.	Length	Width	Height
28190140	410x350	650	360	1065

This trolley is part of our Wheely line.



VERSATILE ALL-PURPOSE TROLLEYS

TABLE TROLLEYS

Practical trolleys with various designs. Ends made of 22 mm tubing with chrome finish or powder-coated light grey or black textured finish. Max. load: 150 kg. Max. load per shelf: 100 kg. Four swivel wheels with grey rubber tyres measuring 100x25 mm, slide bearing hubs. Two of the wheels have brakes. Black or grey powder-coated brackets.

TWO HANDLES, TWO OR THREE SHELVES

Light grey	Black	Chrome	Laminate	Shelves	Shelf dim.	Length	Width	Height
24742021	24743021	24741021	Grey	2	800x420	1024	460	946
24742022	24743022	24741022	Beech/Cherry	2	800x420	1024	460	946
24742023	24743023	24741023	Oak/Birch	2	800x420	1024	460	946
24742121	24743121	24741121	Grey	2	1000x420	1224	460	946
24742122	24743122	24741122	Beech/Cherry	2	1000x420	1224	460	946
24742123	24743123	24741123	Oak/Birch	2	1000x420	1224	460	946

Light grey	Black	Chrome	Laminate	Shelves	Shelf dim.	Length	Width	Height
24762031	24763031	24761031	Grey	3	800x420	1024	460	946
24762032	24763032	24761032	Beech/Cherry	3	800x420	1024	460	946
24762033	24763033	24761033	Oak/Birch	3	800x420	1024	460	946
24762131	24763131	24761131	Grey	3	1000x420	1224	460	946
24762132	24763132	24761132	Beech/Cherry	3	1000x420	1224	460	946
24762133	24763133	24761133	Oak/Birch	3	1000x420	1224	460	946



ONE HANDLE AND ONE END PANEL, TWO OR THREE SHELVES

Light grey	Black	Chrome	Laminate	Shelves	Shelf dim.	Length	Width	Height
24732021	24733021	24731021	Grey	2	800x420	929	460	946
24732022	24733022	24731022	Beech/Cherry	2	800x420	929	460	946
24732023	24733023	24731023	Oak/Birch	2	800x420	929	460	946
24732121	24733121	24731121	Grey	2	1000x420	1129	460	946
24732122	24733122	24731122	Beech/Cherry	2	1000x420	1129	460	946
24732123	24733123	24731123	Oak/Birch	2	1000x420	1129	460	946

Light grey	Black	Chrome	Laminate	Shelves	Shelf dim.	Length	Width	Height
24752031	24753031	24751031	Grey	3	800x420	929	460	946
24752032	24753032	24751032	Beech/Cherry	3	800x420	929	460	946
24752033	24753033	24751033	Oak/Birch	3	800x420	929	460	946
24752131	24753131	24751131	Grey	3	1000x420	1129	460	946
24752132	24753132	24751132	Beech/Cherry	3	1000x420	1129	460	946
24752133	24753133	24751133	Oak/Birch	3	1000x420	1129	460	946





Grey Beech/Cherry Oak/Birch



ONE HANDLE, TWO SHELVES

Light grey	Black	Chrome	Laminate	Shelves	Shelf dim.	Length	Width	Height
24722021	24723021	24721021	Grey	2	800x420	929	460	946
24722022	24723022	24721022	Beech/Cherry	2	800x420	929	460	946
24722023	24723023	24721023	Oak/Birch	2	800x420	929	460	946
24722121	24723121	24721121	Grey	2	1000x420	1129	460	946
24722122	24723122	24721122	Beech/Cherry	2	1000x420	1129	460	946
24722123	24723123	24721123	Oak/Birch	2	1000x420	1129	460	946

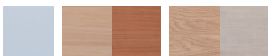

Grey Beech/Cherry Oak/Birch



WITHOUT HANDLES, TWO SHELVES

Light grey	Black	Chrome	Laminate	Shelves	Shelf dim.	Length	Width	Height
24712021	24713021	24711021	Grey	2	800x420	834	460	780
24712022	24713022	24711022	Beech/Cherry	2	800x420	834	460	780
24712023	24713023	24711023	Oak/Birch	2	800x420	834	460	780
24712121	24713121	24711121	Grey	2	1000x420	1034	460	780
24712122	24713122	24711122	Beech/Cherry	2	1000x420	1034	460	780
24712123	24713123	24711123	Oak/Birch	2	1000x420	1034	460	780

ACCESSORIES – TABLE TROLLEYS



MEMO BOARD

With document clip. Pen tray at top.

Art. no.	Description
12200220	Portrait A4



SHELF PARTITION

Easy to move and remove.
Wire distance: 34 mm.

Art. no.	Dimensions
12200104	420x220



BOX

Pulls out. Can be mounted on right or left side.

Art. no.	Dimensions
12200441	370x150x100



SAFETY WHEELS

Protects trolleys, shelves and walls from damage. Set of four wheels for mounting on corner uprights. Only available when ordering new trolleys.

Art. no.
12212010



GRID RAIL

Chrome grid rail. Easy to install and remove. For mounting inside edge strip. Internal shelf measurements: 788x365 mm. Only for 800 mm long trolley. Wire distance: 20 mm.

Art. no.	Dimensions
12621210	800x420x100

FAST AND PRACTICAL

SCOOTERS AND PEDAL BIKES

With our bikes and scooters, you can just kick and go – even if you work in a large building. If you think how much time you save each time compared to walking, it's not hard to see the increase in efficiency in the slightly longer term. If it is not just yourself you need to move, you can choose a pedal bike or scooter with a platform.



SCOOTER MODEL 86

Chassis made of 22 mm shiny zinc-coated tubing. Rubber handles. Hard-wearing 12 mm shelves with light grey laminate finish. Rubber strip around platform frame, detachable restraining rail. Max. load: 150 kg. Max. load, shelf: 50 kg. Three wheels with grey elastic rubber tyres 200x46 mm, ball bearing hubs. Bell included as standard. Effective foot brake regulates back wheel, leaving both hands free for steering.



Art. no.	Shelf dim.	Length	Width	Height to platform
24199086	680x580	1430	680	270

Art. no.	Description
07013470	Front wheel, part number
07013471	Back wheel, part number

SCOOTER MODEL 87

Chassis made of 22 mm shiny zinc-coated tubing. Rubber handles. Shelf thickness: 12 mm. Durable light grey laminate finish. Platform frame made of 22 mm tubing. Max. load: 150 kg. Max. load, shelf: 50 kg. Three wheels with grey elastic rubber tyres 200x46 mm, roller bearing hubs. Equipped with bell as standard. Effective foot brake regulates back wheel, leaving both hands free for steering.



Art. no.	Shelf dim.	Length	Width	Height to platform
24199087	680x580	1430	680	270

Art. no.	Description
07013470	Front wheel, part number
07013471	Back wheel, part number



SCOOTER MODEL 65

Chassis made of 22 mm shiny zinc-coated tubing. Rubber handles. Equipped with parking stand that folds out using the handlebars. Pneumatic front wheel 310x55 mm, back wheel with grey elastic tyre 200x50 mm, ball bearing hub. Equipped with bell and basket as standard. Drum brake on front wheel.

Art. no.
24199065

Art. no.	Description
12200375	Puncture-proof front wheel, on purchase of new bike
07019032	Puncture-proof front wheel, part number



SCOOTER MODEL 10

Chassis made of 22 mm shiny zinc-coated tubing. Pneumatic front wheel 310x55 mm, back wheel with grey elastic tyre 200x50 mm, ball bearing hub. Equipped with bell and basket as standard. Drum brake on front wheel.

Art. no.
24199210

Art. no.	Description
12200375	Puncture-proof front wheel, on purchase of new bike
07019032	Puncture-proof front wheel, part number



PEDAL BIKE MODEL 20

Chassis made of 22 mm shiny zinc-coated tubing. Rubber handles. Hard-wearing 12 mm shelves with light grey laminate finish. Max load, platform: 50 kg. Two front wheels with grey elastic rubber tyres 200x50 mm, ball bearing hubs. Pneumatic back wheel 400x40 mm. Equipped with bell as standard. Hub brake.

Art. no.	Shelf dim.
24199220	610x520

ACCESSORIES – SCOOTERS AND PEDAL BIKES



MEMO BOARD
With document clip and integrated pen tray.

Art. no.	Description
12200220	Portrait A4



BASKET
Wire distance 25 mm. Open corners. For holding small objects.

Art. no.	Dimensions
12299084	150x330x180



UPPER SHELF
Folds out, height-adjustable. For holding light objects.

Art. no.	Dimensions
12299082	660x425



GUARD RAILS
Tube guard rails can easily be detached as necessary. The solid guard rail is non-detachable. Keeps load in place.

Art. no.	Description	Dimensions (intern.)
12299080	Tube guard rail	612x524x70
12299081	Solid guard rail	612x524x118



LOCK
Attaches easily to handlebars.

Art. no.	Compatible with
07090435	Model 86, 87 and 20
12299030	Model 65 and 10

FAST AND SIMPLE TO USE

CLOTHES RAILS AND SHOP TROLLEYS

Our clothing rails and baskets for shops, makes handling smooth and save space. The rails are stackable and the baskets are foldable. With timeless design they fit most environments.



CLOTHES RAIL ING-MARIE, SHORT

Shiny zinc-coated square steel tubing. Chassis: 50x25 mm. Upright: 40x20 mm. Clothes bar made of 22 mm tubing. Max. load: 100 kg per bar and max. 150 kg. Four swivel wheels with grey rubber tyres measuring 100x25 mm, slide bearing hubs. Handlebars are standard on two-level clothes rail. Also available as accessory.

Art. no.	Levels	Length	Width	Height
24197660	1	1066	606	1670
24197760	2	1066	606	1940

Handlebars	
Art. no.	Quantity
12297630	1 piece

CLOTHES RAIL ING-MARIE, LONG

Shiny zinc-coated square steel tubing. Chassis 50x25 mm. Upright 40x20 mm. Clothes bar made of 30 mm tubing. Shiny zinc-coated handlebars with rubber grips. Max. load: 100 kg per bar and max. 200 kg. Four swivel wheels with grey rubber tyres measuring 125x32 mm, ball bearing hubs. Handlebars are standard on two-level clothes rail. Also available as accessory.

Art. no.	Levels	Length	Width	Height
24197662	1	1530	606	1710
24197762	2	1530	606	1980

Handlebars	
Art. no.	Quantity
12297630	1 piece



CLOTHES RAIL
Z-FRAME, SMALL WHEELS

Shiny zinc-coated square steel tubing. Chassis: 50x25 mm. Upright: 40x20 mm. Clothes bar 20x40 mm, flat oval. Max. load: 100 kg per bar and max. 150 kg. Four swivel wheels with grey rubber tyres measuring 100x25 mm, slide bearing hubs.

Art. no.	Levels	Length	Width	Height
24197250	1	1530	660	1640
24197450	2	1530	660	2000



CLOTHES RAIL
Z-FRAME, LARGE WHEELS

Shiny zinc-coated square steel tubing. Chassis: 25x25 mm. Upright: 40x20 mm. Clothes bar 20x40 mm, flat oval. Max. load: 100 kg per bar and max. 200 kg. Four swivel wheels with grey rubber tyres measuring 125x32 mm, ball bearing hubs.

Art. no.	Levels	Length	Width	Height
24197252	1	1530	660	1670
24197452	2	1530	660	2030



CLOTHES RAIL WITH
HEAVY DUTY CHASSIS, SMALL WHEELS

Shiny zinc-coated square steel tubing. Chassis 25x25 mm. Upright 40x20 mm. Clothes bar 20x40 mm, flat oval. Max. load: 100 kg per bar and max. 200 kg. Four swivel wheels with grey rubber tyres measuring 125x32 mm, ball bearing hubs.

Art. no.	Levels	Length	Width	Height
24197352	1	1570	630	1650
24197552	2	1570	630	2010



CLOTHES RAIL WITH
HEAVY DUTY CHASSIS, LARGE WHEELS

Shiny zinc-coated square steel tubing. Chassis 25x25 mm. Upright 40x20 mm. Clothes bar 20x40 mm, flat oval. Max. load: 100 kg per bar and max. 200 kg. Four swivel wheels with black rubber tyres measuring 200x50 mm, roller bearing hubs.

Art. no.	Levels	Length	Width	Height
24197357	1	1570	630	1740
24197557	2	1570	630	2100



CLOTHES RAIL AMANDA

Shiny zinc-coated 22 mm tubing. Max. load 100 kg. Four swivel wheels, ø50 mm, in black plastic. Delivered in a smooth, flat package, weighing only 5 kg.

Art. no.	Length	Width	Height
28197110	1050	530	1575

This trolley is part of our Wheely line.



COLLAPSIBLE TROLLEY WITH GRID SHELVES, SMALL

Chassis made of powder-coated 19 mm tubing. Mesh size 67x95 mm. One detachable grid shelf adjustable in different positions. Thickness 25 mm, mesh size 64x78 mm. Max. load: 100 kg. Four swivel wheels with grey rubber tyres, 100x25 mm, slide bearing hubs. With the shelf detached, the trolley can be folded to a thickness of just 50 mm. Folded length: 1160 mm.

Art. no.	Dimension	Length	Width	Height
28622000	600x550	600	550	790

This trolley is part of our Wheely line.



COLLAPSIBLE TROLLEY WITH GRID SHELVES, LARGE

Chassis made of powder-coated 19 mm tubing. Mesh size 67x95 mm. One detachable grid shelf adjustable in different positions. Thickness 25 mm, mesh size 64x78 mm. Max load 100 kg. Four swivel wheels with grey rubber tyres, 100x25 mm, slide bearing hubs. With the shelf detached, the trolley can be folded to a thickness of just 50 mm. Folded length: 1460 mm.

Art. no.	Dimension	Length	Width	Height
28622010	900x550	900	550	790

This trolley is part of our Wheely line.

CLEAN AND SIMPLE

REFUSE BAG TROLLEYS

Our refuse bag trolleys are ideal for separating and recycling waste in offices and industrial environments. Compatible with 125 litre refuse bags. The bag holder is continuously height-adjustable.



REFUSE BAG TROLLEY, STANDARD

Chassis made of 22 mm shiny zinc-coated tubing. Four swivel wheels with grey rubber tyres measuring 100x25 mm. Trolley with handles has slide bearing hubs, trolley without handles has four plastic wheels measuring 50 mm in diameter.

Art. no.	Length	Width	Height	Description
24193300	650	360	1060	With handles
24193305	650	360	1060	Without handles



REFUSE BAG TROLLEY WITH LID

Chassis made of 22 mm shiny zinc-coated tubing. Four plastic wheels measuring 50 mm in diameter.

Art. no.	Length	Width	Height	Description
24193310	650	360	1060	With lid



REFUSE BAG TROLLEY FOR TWO BAGS

Chassis made of 22 mm shiny zinc-coated tubing. Four swivel wheels with grey rubber tyres measuring 100x25 mm, slide bearing hubs. Delivered ready-assembled.

Art. no.	Length	Width	Height	Description
14119310	800	460	1140	For two bags

FOR SAFE CONDUCTION OF STATIC ELECTRICITY

ESD TROLLEYS

Special ESD-protected trolleys for environments with special requirements EPA-ESD-Protected Areas. These trolleys are designed for safe conduction of static electricity. They are approved by the Swedish Testing and Research Institute (SP) according to SP-Method 2472, and meet IEC 61340-5-1 and N 100015-1 requirements. The shelves are made of 19 mm conductive panel, melamine-coated on both sides. Black ABS edge strip on all four sides. The shelves and handles are continuously adjustable and can easily be adapted to your needs.



ESD SHELF TROLLEY SERIES 100

Max. load: 200 kg. Max. load, shelves: 100 kg. Four swivel wheels measuring 125x32 mm with ball bearing hubs and safety guard. Extra shelves can be added.

Art. no.	Shelves	Shelf dim.	Length	Width	Height
34112222	2	620x430	800	460	1120
34112322	2	750x430	930	460	1120
34112522	2	1000x430	1180	460	1120
34112622	2	1200x430	1380	460	1120
34112332	3	620x430	800	460	1120
34112332	3	750x430	930	460	1120
34112532	3	1000x430	1180	460	1120
34112632	3	1200x430	1380	460	1120
34112242	4	620x430	800	460	1585
34112342	4	750x430	930	460	1585
34112542	4	1000x430	1180	460	1585
34112642	4	1200x430	1380	460	1585



Load restrainer

Art. no.	Length
12212254	620
12212261	750
12212262	1000
12212263	1200

Art. no.	Description
12200306	Brakes on four wheels

If you want the trolley to be delivered unassembled with an approval document enclosed, replace the number 34 with 36 at the beginning of the article number.

ESD SHELF TROLLEY SERIES 300

Two fixed wheels and two swivel wheels ensure optimum driving stability. Slightly larger sized wheels combined with a sturdy chassis make this trolley easy to drive even with heavy loads. Max. load: 300 kg. Max. load, lower shelf: 300 kg. Max. load, upper shelves: 100 kg. Two fixed wheels, two swivel wheels 200x50 mm with roller bearing hubs. Extra shelves can be added.

Model 22 – low ends, 2 shelves

Model 24 – high ends, 4 shelves



Load restrainer	
Art. no.	Length
12212256	800
12212258	1200
12212259	1400
12212260	1600

Art. no.	Description
12200306	Brakes on four wheels

Art. no.	Shelves	Shelf dim.	Length	Width	Height
35220623	2	800x620	990	650	1070
35221623	2	1000x620	1190	650	1070
35222623	2	1200x620	1390	650	1070
35224623	2	1400x620	1590	650	1070
35226623	2	1600x620	1790	650	1070

Art. no.	Shelves	Shelf dim.	Length	Width	Height
35240643	4	800x620	990	650	1730
35241643	4	1000x620	1190	650	1730
35242643	4	1200x620	1390	650	1730
35244643	4	1400x620	1590	650	1730
35246643	4	1600x620	1790	650	1730

If you want the trolley to be delivered unassembled with an approval document enclosed, replace the number 35 with 37 at the beginning of the article number.



ESD SHELF TROLLEY SERIES 400

Two fixed wheels and two swivel wheels ensure optimum driving stability. Slightly larger sized wheels combined with a sturdy chassis make this trolley easy to drive even with heavy loads. The ends and shelves are reinforced to withstand loads up to 500 kg. Max. load: 500 kg. Max. load, lower shelf: 500 kg. Max. load, upper shelves: 150 kg. Two fixed wheels, two swivel wheels 200x50 mm with roller bearing hubs. Extra shelves can be added.

Model 25 – low ends, 2 shelves

Model 27 – high ends, 3 shelves



Load restrainer

Art. no.	Length
12212256	800
12212258	1200
12212259	1400
12212260	1600

Art. no.	Description
12200306	Brakes on four wheels

Model 25

Art. no.	Shelves	Shelf dim.	Length	Width	Height
35250525	2	800x520	1000	570	1180
35251525	2	1000x520	1200	570	1180
35252525	2	1200x520	1400	570	1180
35250625	2	800x620	1000	650	1180
35251625	2	1000x620	1200	650	1180
35252625	2	1200x620	1400	650	1180
35254625	2	1400x620	1600	650	1180
35256625	2	1600x620	1800	650	1180
35251725	2	1000x720	1200	750	1180
35252725	2	1200x720	1400	750	1180
35254725	2	1400x720	1600	750	1180
35256725	2	1600x720	1800	750	1180
35252825	2	1200x820	1400	850	1180
35254825	2	1400x820	1600	850	1180
35256825	2	1600x820	1800	850	1180

Model 27

Art. no.	Shelves	Shelf dim.	Length	Width	Height
35270535	3	800x520	1000	570	1860
35271535	3	1000x520	1200	570	1860
35272535	3	1200x520	1400	570	1860
35270635	3	800x620	1000	650	1860
35271635	3	1000x620	1200	650	1860
35272635	3	1200x620	1400	650	1860
35274635	3	1400x620	1600	650	1860
35276635	3	1600x620	1800	650	1860
35271735	3	1000x720	1200	750	1860
35272735	3	1200x720	1400	750	1860
35274735	3	1400x720	1600	750	1860
35276735	3	1600x720	1800	750	1860
35272835	3	1200x820	1400	850	1860
35274835	3	1400x820	1600	850	1860
35276835	3	1600x820	1800	850	1860

If you want the trolley to be delivered unassembled with an approval document enclosed, replace the number 35 with 37 at the beginning of the article number.



ESD MOBILE TABLE

Chassis of 22 mm round, shiny zinc-coated tubing. Max. load: 100 kg. Max. load, upper shelf: 100 kg for large table, 50 kg for small table. Four swivel wheels 125x32 mm with ball bearing hubs and safety guard.

Art. no.	Shelves	Shelf dim.	Length	Width	Height
34171120	2	600x430	405	385	1100
34172312	2	820x600	750	430	900
34172612	2	1200x600	750	430	900

If you want the trolley to be delivered unassembled with an approval document enclosed, replace the number 34 with 36 at the beginning of the article number.



ESD TABLE TROLLEY

Chassis made of 22 mm shiny zinc-coated tubing with rounded edges. Max. load: 150 kg. Max. load, upper shelf: 100 kg. Four swivel wheels 125x32 mm with ball bearing hubs and safety guard.

Art. no.	Shelves	Shelf dim.	Length	Width	Height
34734023	2	800x430	1140	460	980
34734033	3	800x430	1140	460	980

If you want the trolley to be delivered unassembled with an approval document enclosed, replace the number 34 with 36 at the beginning of the article number.



ESD BOX DOLLY

Adapted to fit boxes measuring 600x400 mm or 800x600. The rounded frame provides a practical carrying grip. Max. load 400 kg. Four swivel wheels measuring 125x32 mm with ball bearing hubs. Delivered ready-assembled.

Art. no.	Length	Width	Height	Box dimensions
34184826	660	440	180	600x400
34184836	860	640	180	800x600



ESD BOX TROLLEY

Angled 25 mm guide rails for up to 8 boxes 600x400 mm. Height between guide rails 165 mm. Max. load: 200 kg. Four swivel wheels, 125x32 mm with ball bearing hubs.

Art. no.	Length	Width	Height
34119182	670	465	1585

If you want the trolley to be delivered unassembled with an approval document enclosed, replace the number 34 with 36 at the beginning of the article number.

FLEXIBLE E-COMMERCE SOLUTIONS

E-COMMERCE TROLLEYS

When picking several orders at the same time, our eCommerce trolley is a flexible solution, where shelf dividers are easily added, adjusted or removed. The side grid is also removable and can be mounted on either the right or the left side depending on your own requirements. Depending on the aisle width and goods' size, the trolleys are made in two different widths. The centre-wheels' equipment makes the trolley easy to manoeuvre even with one hand and makes it easy to turn also with heavy load. Other sizes or power supply equipment etc available on request.



To find out more about our smart eCommerce solutions, please contact our sales department at info@helge-nyberg.com, or call +46 321 263 00.

ERGONOMIC AND EFFICIENT

MOTORISED TROLLEYS

An electric trolley makes your work easier. Take care of your body. Stopping and starting a heavy trolley without an engine can cause repetitive strain injuries, for instance to shoulders. Use of electric trolleys reduces employee sick leave rates.

ELECTRIC TROLLEY

An electric engine can be installed on our trolleys with a height of 600 and 800 mm and a length of 1200, 1400 and 1600 mm (series 300 & 400). The electric engine is installed underneath the trolley chassis, so it doesn't encroach on the trolley's loading space. The engine is a registered design. Other sizes and customised versions are available on request.



Double ergonomic grip adjustment

Art. no.

12375002 Stepless back/forward operating unit

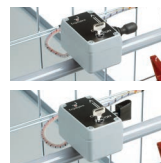

Standard joystick

Art. no.

12375000 Back/forward operating unit
12375001 Stepless back/forward operating unit

Technical data

Towing capacity Electric engine for max. load 500 kg.
Control Back/forward operating unit operated with joystick or on/off switch.
Power supply 25 Ah or 50 Ah gel batteries. Charger 7A or 8A.
Max. speed 5 kph
Performance The operating box can be programmed for acceleration, brakes, speed backwards and forwards etc.

Art. no.

12371600 Electric engine width 600 mm. Max. 500 kg.
12372800 Electric engine width 600 mm. Max. 500 kg.
12376001 Charger 7A
12376001 Charger 8A
12377001 Set of batteries 25 Ah
12377000 Set of batteries 50 Ah

SOLUTIONS ADAPTED TO YOUR

Despite our wide standard range of trucks and trolleys, customers sometimes still need tailor-made solutions. That's no problem for us. One of the secrets behind Helge Nyberg's success is that we have the resources and organisation to develop products and solutions according to customers' specific requirements. We have experienced product developers, expert assembly mechanics, a wealth of solid craftsmanship, know-how and expertise regarding logistics and light material handling. There are many advantages of having your own manufacturing facilities and R&D department.

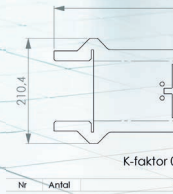

For a German mail order company, we developed this batch picking trolley that quickly and efficiently handles multiple batches of small goods.

The steadily growing e-commerce sector requires efficient goods handling solutions. Here is one example of a trolley specially developed for picking orders.

This manual step trolley has been specially developed for replenishment of articles packed in boxes, often stored in narrow aisles.

UNIQUE NEEDS

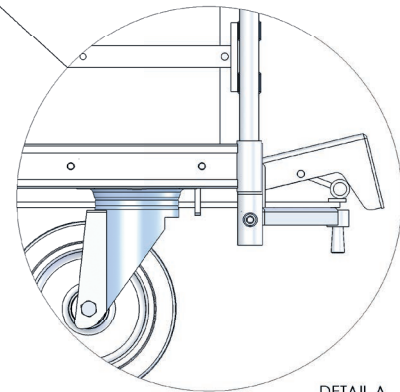
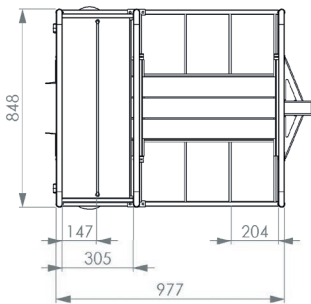
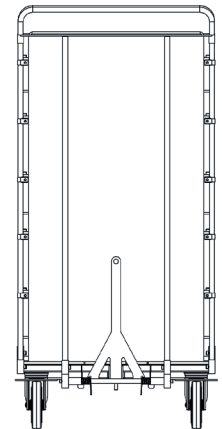
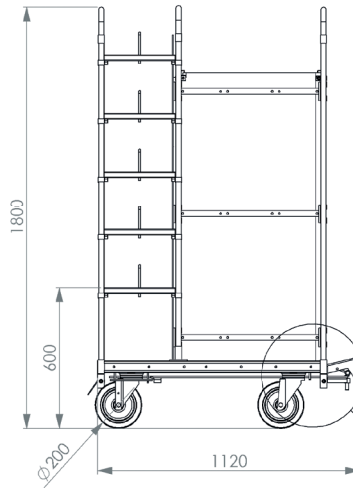
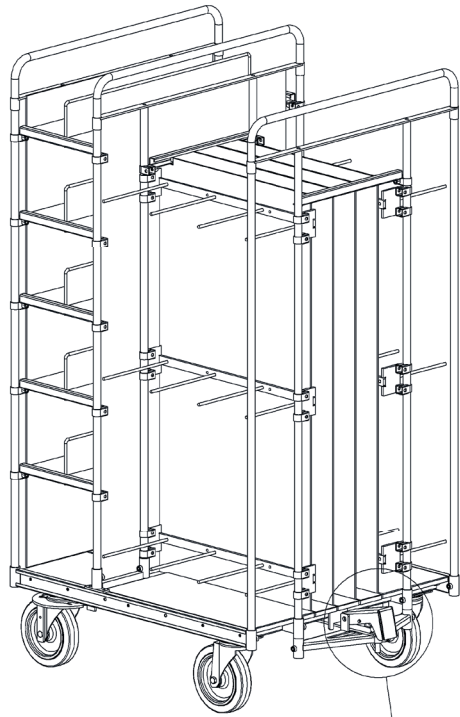
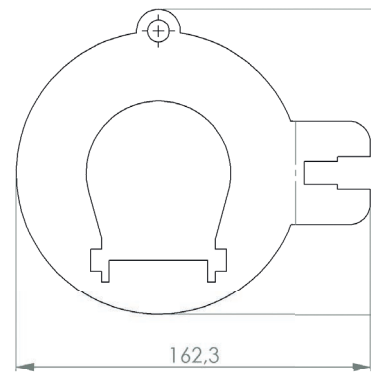

DETAIL A
SCALE 1 : 4

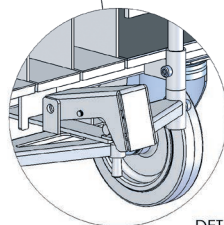

DETAIL B
SCALE 1 : 5

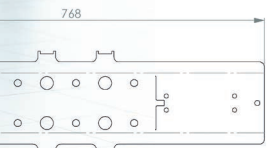

333
Ändring / anmärkning Datum Inf



We have produced this smart truck solution provides more efficient picking of containers within industries such as FMCG. It can also be combined with Taxi Flex solution for containers.



Anyone who has been inside a regional state archive knows how large and heavy documents, folders and books can be. We created an extra sturdy trolley with room for many books, steps and a worktop for reading.



For another mail order company, we developed and manufactured trolleys for batch picking of large goods. The trolley tips the loaded goods onto a conveyor, which transports them to a sorting station.

GENERAL PURCHASING CONDITIONS

(For purchasing of trolleys from Helge Nyberg AB) – The warranty regards trolleys

LIFETIME WARRANTY

Helge Nyberg AB offers a lifetime warranty on all trolleys in the Ergobjörn standard range. This lifetime warranty does not cover ESD trolleys (see below), customised trolleys, non-standard product variants, Wheely products or motorised products.

Under the lifetime warranty, Helge Nyberg AB assumes responsibility, for the duration of Helge Nyberg AB's lifetime, for any faults and failures that may arise in the product due to faults in design, materials or production (manufacturing defects).

Under the lifetime warranty, Helge Nyberg AB undertakes to provide the buyer with replacements of parts that cause the trolley to malfunction, at Helge Nyberg AB's expense.

The warranty does not cover faults and failures caused by the buyer using the trolley in violation of Helge Nyberg AB's instructions. Neither does the warranty cover faults caused by inadequate maintenance or incorrect assembly by the buyer, changes made without Helge Nyberg AB's

written approval or faulty repairs carried out by the buyer. Finally, the guarantee does not cover normal wear or deterioration.

The terms and conditions of the guarantee as written above are exhaustive. Helge Nyberg AB disclaims all responsibility beyond the scope of what is written above.

The warranty covers trolleys invoiced from 1 August 1997.

ESD TROLLEYS 5-YEAR WARRANTY

The warranty for ESD trolleys is the same as specified for standard trolleys, with the following exceptions:

The warranty will be valid for five (5) years from the date it was supplied to the buyer. The trolleys are approved by the Swedish Testing and Research Institute (SP) and meet the requirements of SP-Method 2472.

The trolleys' conductive properties are only guaranteed if the maintenance instructions and warranty certificate are complied with.

ELECTRICALLY POWERED PRODUCTS HAVE A 1-YEAR WARRANTY.

The warranty for electrically powered products is the same as specified above for standard trolleys, with the following exceptions:

The warranty is valid for one (1) year from the date the product was supplied to the buyer.

SPARE PARTS AND REPLACEMENT PARTS

The warranty specified above applies to spare parts for trolleys from our standard range, except that the warranty expires ten (10) years after the date the product was delivered to the buyer.

For spare parts and replacement parts for all other trolleys, the warranty is valid for one (1) year.



THINGS TO THINK ABOUT BEFORE BUYING A TROLLEY

Since 1958, we have been developing and manufacturing trolleys that have saved large amounts of money and countless backs. For this reason, we know how important it is to ask the right questions before investing in a material handling solution. To help you, we have compiled a list of questions we would like you to ask yourself. As specialists in in-house material handling, we know how to make transportation more cost-effective in sectors including industrial manufacturing, health care, warehouses and offices premises.



WHAT MATERIALS WILL YOU BE HANDLING?

The shape and weight of the materials should determine the shelf size you choose.

HOW WILL THE MATERIAL BE HANDLED?

With the material be unsorted, stacked, sorted into compartments, boxes, crates, plastic trays or handled in other ways?

WHAT IS YOUR WORK ENVIRONMENT LIKE?

The trolley's total dimensions should suit the widths of your aisles, lifts and doors.

IS THE SOLUTION FLEXIBLE?

The solution you invest in must be flexible and adaptable to changing circumstances. How adaptable are your solutions? Are suitable accessories available?

WHAT ARE YOUR ERGONOMIC REQUIREMENTS?

Can the trolley solution be adapted to your industry and the needs of your employees?

TRANSPORT DISTANCE AND FREQUENCY

A solution that is too powerful for your needs is as uneconomical as one that is not powerful enough.

WHO WILL PERFORM THE MATERIAL HANDLING?

Your employees are the ones who make sure that everything works, so they need to feel comfortable with the solution.

INDEX

Innovative visions	2-3
Five decades of experience	4-5
A specialist on several areas	6-7
Ergobjörn products - suitable for you	8-9

TROLLEYS FOR TOW TRUCKS

Shelf trolleys models 25 & 27	10
Platform trolley models 54 & 55	11
Parcel trolley	11

ACCESSORIES TROLLEYS FOR TOW TRUCKS

Memo board	12
Push brake	12
Truck fork guide	12
Protective edging strip	12
Grid rail	12
Extra shelves for models 25 & 27	12
Side grid	12
Shelf partition	12

TAXI FLEX

Taxi Flex	13
-----------------	----

INTRODUCTION TAXI SOLUTIONS

14-15

TAXI SOLUTIONS

Taxi trolleys	16
Full pallet dolly	17
Half pallet dolly	17
Shelf system	17

TAXI FLEX

Taxi Flex	18-19
-----------------	-------

THE SOLUTIONS OF THE FUTURE ARE HERE

Smart and efficient distribution	20-21
--	-------

INTRODUCTION TROLLEYS

22-23

SHELF TROLLEYS

Shelf trolley series 100	24
Grid trolley series 100	24
Shelf trolley series 100 – popular	25
Shelf trolley series 200	25

ACCESSORIES SERIES 100 & 200 SHELF TROLLEYS

Memo board	26
Pen tray	26
Grid rail	26
Basket	26
Side grid	26
Shelf partition	26
Box	26
Safety wheels	26

SHELF TROLLEYS

Shelf trolley black – 3 shelves	27
Shelf trolley black – 4 shelves	27
Shelf trolley series 300 model 22 & 24	28
Shelf trolley series 300 model 11 & 12	28

ACCESSORIES SERIES 300 SHELF TROLLEYS

Grid rail	29
Side grid	29
Memo board	29
Basket	29
Shelf partition	29
Steps	29
Protective edging strip	29
Truck fork guide	29
Support wheel system	29

SHELF TROLLEYS

Shelf trolley series 400	30
--------------------------------	----

ACCESSORIES SERIES 400 SHELF TROLLEY

Grid rail	31
Side grid	31
End grid	31
Basket	31
Shelf partition	31
Memo board	31
Protective edging strip	32
Support wheel system	32
Truck fork guide	32
Steps	32
Tow bar	32
Tow hook	32

STEP TROLLEYS

Step trolley series 100	33
Step trolley series 200	33

ACCESSORIES SERIES 100 & 200 STEP TROLLEYS

Grid rail	34
Basket	34
Memo board	34
Pen tray	34
Shelf partition	34
Box	34
Safety wheels	34

PLATFORM TROLLEYS

Platform trolley series 100	35
Platform trolley series 200	35
Platform trolley series 300	36
Platform trolley series 400 model 54 & 55	36

ACCESSORIES PLATFORM TROLLEYS

Memo board	37
Basket	37
Protecting edging strip	37
Pen tray	37

PARCEL TROLLEYS

Parcel trolley series 100	38
Parcel trolley series 300	39
Parcel trolley series 400	39

ACCESSORIES PARCEL TROLLEYS

Memo board	40
Basket	40
Pen tray	40
Safety wheels	40
Protective edging strip	40
Support wheel system	40

ALTERNATIVE WHEELS / ACCESSORIES AND SPARE PARTS FOR SERIES 100 & 200

Swivel wheels 150 x 32	41
Swivel wheels 150 x 30	41
Wheels with double brakes	41
Wheels with disconnectable lock	41
Solid rubber wheels	41
Nylon wheels	41
Elastic wheels	41

ACCESSORIES AND SPARE PARTS FOR SERIES 300

Grey wheels	42
Wheels with double brakes	42
Pneumatic wheels	42
Nylon wheels	42
Elastic wheels	42

ACCESSORIES AND SPARE PARTS FOR SERIES 400

Grey wheels	43
Wheels with double brakes	43
Pneumatic wheels	43
Nylon wheels	43
Elastic wheels	43

BOX TROLLEYS AND DOLLIES

Full pallet dolly	44
Half pallet dolly	44
Pallet dolly, full and half pallet	44
Small steel tube dolly	45
Large steel tube dolly	45
Sheet metal dolly	45
Large wire dolly	45
Small wire dolly	45
Box trolley	46
Box trolley Flex	46
Assembly trolley	46
Extra high platform trolley	47
Dolly with handle	47
Extra high dolly	47

OFFICE TROLLEYS

File trolley, short	48
File trolley, long	48
File trolley, short with topshelf	49
File trolley, long with topshelf	49
Filing trolley, beech, three file shelves	50
Filing trolley, beech, two file shelves and product resting shelf	50
Shelf trolley black	51
File trolley black	51
Basket trolley black	51
Mobile table large	52
Mobile table medium	52
Mobile table small	52

ACCESSORIES MOBILE TROLLEY

File shelf/file support	53
Extra shelves	53
Box	53
Wheel brake	53

OFFICE TROLLEYS

Office trolley exclusive	54
Post trolley large.....	54
Post trolley small	54
Mini trolley, two shelves.....	55
Mini trolley, two baskets	55
Mini trolley, one shelf, one basket	55
Mini trolley black, two shelves.....	56
Mini trolley black, two baskets	56
Mini trolley black, one shelf, one basket	56

TABLE TROLLEYS

Without handles, two shelves.....	57
One handle and one end panel, two or three shelves	57
One handle, two shelves	58
Without handles, two shelves	58

ACCESSORIES TABLE TROLLEYS

Memo board	59
Shelf partition	59
Box	59
Safety wheels	59
Grid rail	59

INTRODUCTION SCOOTERS AND PEDAL BIKES 60

SCOOTERS AND PEDAL BIKES

Scooter model 86	61
Scooter model 87	61
Pedal bike model 65	62
Pedal bike model 10	62
Pedal bike model 20	62

ACCESSORIES SCOOTERS AND PEDAL BIKES

Memo board	63
Basket.....	63
Upper shelf.....	63
Guard rails	63
Lock	63

CLOTHES RAILS AND SHOP TROLLEYS

Clothes railing Ing-Marie, long	64
Clothes railing Ing-Marie, short.....	64
Clothes rail z-frame, small wheels	65
Clothes rail z-frame, big wheels	65
Clothes rail with heavy duty chassis, small wheels	65
Clothes rail with heavy duty chassis, big wheels	65
Clothes railing Amanda.....	66
Collapsible trolley with grid shelves, small.....	66
Collapsible trolley with grid shelves, large	66

REFUSE BAG TROLLEYS

Refuse bag trolley, standard	67
Refuse bag trolley with lid	67
Refuse bag trolley for two bags.....	67

ESD-TROLLEYS

ESD shelf trolley series 100	68
ESD shelf trolley series 300	69
ESD shelf trolley series 400	70
ESD mobile table.....	71
ESD box dolly	71
ESD table dolly	71
ESD box trolley	71

E-COMMERCE TROLLEYS..... 72

eCommerce trolleys	72
--------------------------	----

MOTORISED TROLLEYS

Electric trolley.....	73
-----------------------	----

SOLUTIONS ADAPTED 74

Solutions adapted to your unique needs	74-75
General purchasing conditions.....	76
Pick the right trolley.....	77

*We make reservation for deviations and misprints.
Product development is constantly ongoing and therefore we reserve
us the right to make changes in appearance and construction.*



Assembl

IPM Ulricehamn. Photo: Superstudio, Bortäxpressen, M. Kalona and G. Falström

SINCE 1958, Helge Nyberg AB has been developing and manufacturing trolleys and light electric trucks under the name of Ergobjörn for in-house material handling. As specialists, we rationalise the work and costs of warehouses and logistics in sectors including industrial manufacturing, health care, airports and mail order firms.

HelgeNyberg AB

HEAD OFFICE / SWEDEN

Industrivägen 2
SE-523 90 Ulricehamn

Phone +46 321 263 00
Fax +46 321 263 01

info@helge-nyberg.com
www.helge-nyberg.com